



# PARTS CATALOGUE

## T135-5 ( 55D7 ) MALAYSIA

---



1T55D-440E1

( )

T135-5  
PARTS CATALOGUE  
©2017 by Yamaha Motor Co., Ltd.  
1st edition, November 2017  
All rights reserved.  
Any reprinting or unauthorized use  
without the written permission of  
Yamaha Motor Co., Ltd.  
is expressly prohibited.  
Printed in Japan.

# FOREWORD

This Parts Catalogue is related to the parts for the model(s) on the cover page. When you are ordering replacement parts, please refer to this Parts Catalogue and quote both part numbers and part names correctly.

1. Modifications or additions which have been made after the issue of the Parts Catalogue will be announced in the Parts News.  
It is advisable that you make the necessary corrections to the Parts Catalogue according to the Parts News.

2. Abbreviations

The following abbreviations are used in this Parts Catalogue.

“UR” Use specified parts number.

“UN” Use as many as needed.

“AP” Alternate Parts

“LM” Locally Made (Parts need to be ordered locally)

“F#” Frame No. (Applicable machine No.)

“O/S” Over Size

3. The number of components for assembly

- Parts, which are to be supplied in an assembly, are listed with a dot (.) in front of the part name as shown below.
- The numeral appearing to the right of each component part indicates the quantity of parts for each assembly unit.

PART NO.	DESCRIPTION	Q'TY	REMARKS
2F5-83310-60	FRONT FLASHER LIGHT ASSY	2	
115-83311-60	.BULB (6V-18W)	1	

4. Applicable colours of graphics are represented in the “REMARKS” as shown below.

PART NO.	DESCRIPTION	Q'TY	REMARKS
2N4-24110-00-X5	FUEL TANK COMP.	2	MXR
3J1-24240-10	.GRAPHIC, FUEL TANK	1	FOR MXR

5. Note that the illustrations for reference in finding parts numbers are not to be used for assembling. When assembling, please use the applicable service manual.

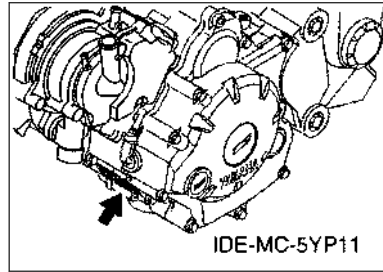
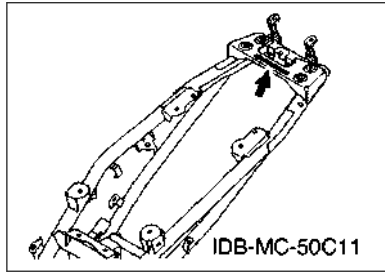
6. The asterisk (\*) before a reference number indicates modified items after the first edition.

# FOREWORD

## 7. Applicable Serial No.

Frame Serial No.

Engine Serial No.



## 8. Applicable Colour Code (The (\*) mark shows Model colour.)

Abbreviation	Colour Name	Colour Code
LLGS6	LIGHT LEAF GREEN SOLID 6	1510
MBL2	MAT BLACK 2	0582
MS1(*)	MAT SILVER 1	1160
RM7(*)	RED METALLIC 7	1218
S3(*)	SILVER 3	0791
SMX(*)	BLACK METALLIC X	0903
VPBC5	VIVID PURPLISH BLUE COCKTAIL 5	1177
YB	YAMAHA BLACK	0033

## 9. Applicable Starting Serial No.

Frame Serial No.

Serial No.	Name Of Q'ty Column	Model Code

Engine Serial No.

Serial No.	Name Of Q'ty Column	Model Code

# CONTENTS

## ENGINE

CYLINDER HEAD.....	1
CRANKSHAFT & PISTON.....	2
VALVE.....	3
CAMSHAFT & CHAIN.....	4
WATER PUMP.....	5
RADIATOR & HOSE.....	6
OIL PUMP.....	7
INTAKE.....	8
CARBURETOR.....	10
EXHAUST.....	12
CRANKCASE.....	13
CRANKCASE COVER 1.....	14
STARTER.....	15
STARTER CLUTCH.....	16
CLUTCH.....	17
TRANSMISSION.....	19
SHIFT CAM & FORK.....	21
SHIFT SHAFT.....	22

## CHASSIS

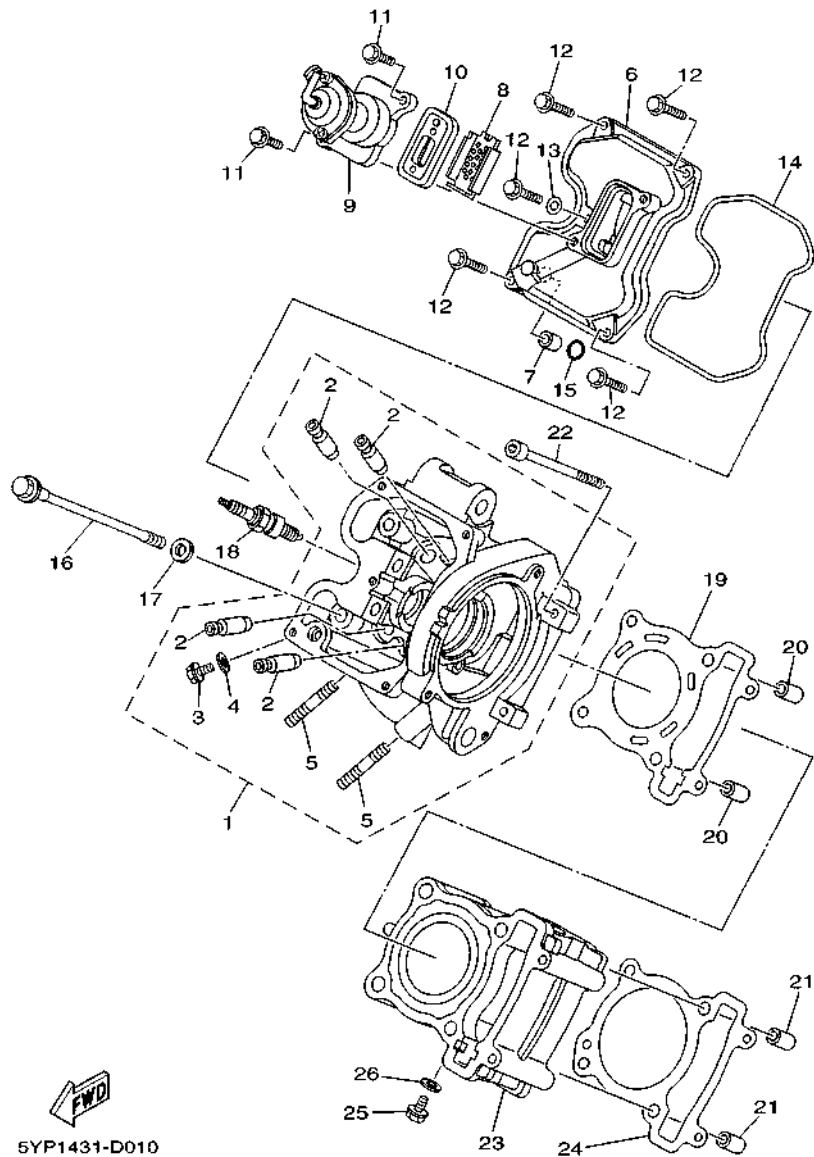
FRAME.....	23
FENDER.....	24
SIDE COVER.....	25
REAR ARM & SUSPENSION.....	28
STEERING.....	29
FRONT FORK.....	30
FUEL TANK.....	31
SEAT.....	32
FRONT WHEEL.....	34
FRONT BRAKE CALIPER.....	35
REAR WHEEL.....	36
STEERING HANDLE & CABLE.....	38
FRONT MASTER CYLINDER.....	40
STAND & FOOTREST.....	41
LEG SHIELD.....	43
GENERATOR.....	46
STARTING MOTOR.....	47
FLASHER LIGHT.....	48
METER.....	49

HEADLIGHT.....	50
TAILLIGHT.....	51
HANDLE SWITCH & LEVER.....	52
ELECTRICAL 1.....	53
ELECTRICAL 2.....	54

## INDEX

NUMERICAL INDEX.....	55
----------------------	----

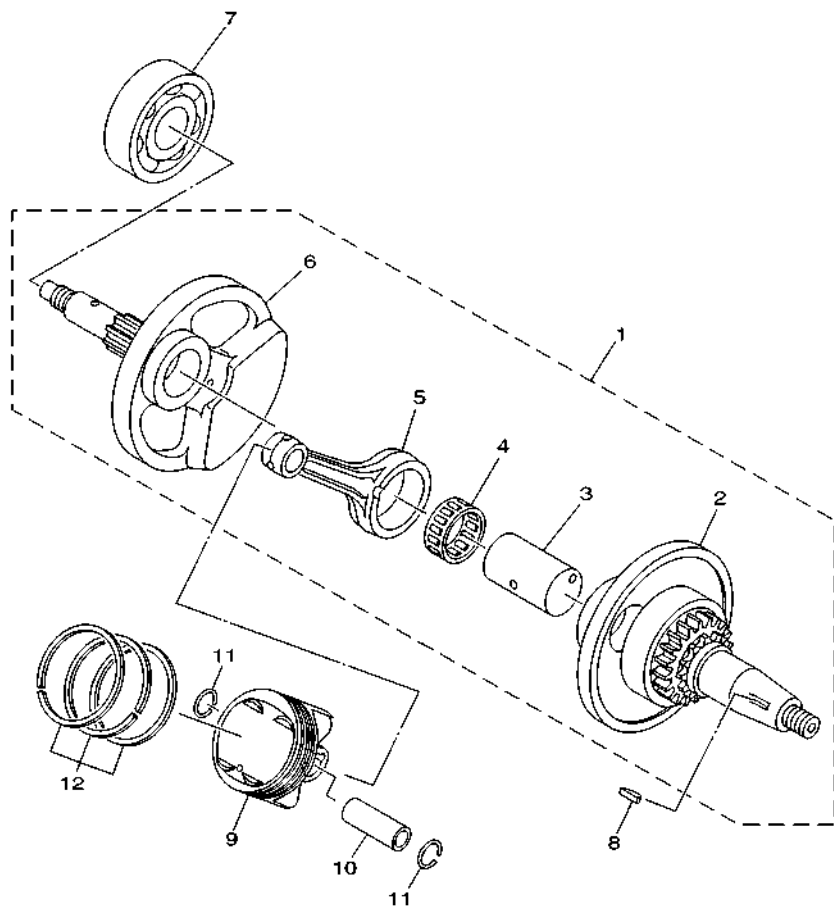
**FIG. 1 CYLINDER HEAD**



5YP1431-D010

REF. NO.	PART NO.	DESCRIPTION	55D7				REMARKS
1	1S8-E1102-00	CYLINDER HEAD ASSY	1				
2	5YP-E1133-10	.GUIDE, VALVE 1	4				
3	90153-06803	.SCREW, HEXAGON	1				
4	90430-06817	.GASKET	1				
5	95617-08620	.BOLT, STUD	2				
6	1S8-E1191-00	COVER, CYLINDER HEAD 1	1				
7	91811-10005	PIN, DOWEL	1				
8	5YP-1482K-00	PLATE	1				
9	5YP-E4840-00	AIR CUT VALVE ASSY	1				
10	5YP-E4890-00	REED VALVE ASSY	1				
11	95027-06014	BOLT, FLANGE	2				
12	95027-06020	BOLT, FLANGE	5				
13	90430-06817	GASKET	1				
14	2PV-E1193-00	GASKET, HEAD COVER 1	1				
15	93210-11802	O-RING	1				
16	90105-08850	BOLT, FLANGE	4				
17	90201-08609	WASHER, PLATE	4				
18	94700-00884	PLUG, SPARK (NGK CPR8EA)	1				
19	1S8-E1181-01	GASKET, CYLINDER HEAD 1	1				
20	99530-10114	PIN, DOWEL	2				
21	99530-10114	PIN, DOWEL	2				
22	91317-06100	BOLT,HEX.SOCKET HEAD	2				
23	50C-E1311-00	CYLINDER 1	1				
24	55D-E1351-00	GASKET, CYLINDER	1				
25	90153-06803	SCREW, HEXAGON	1				
26	90430-06817	GASKET	1				

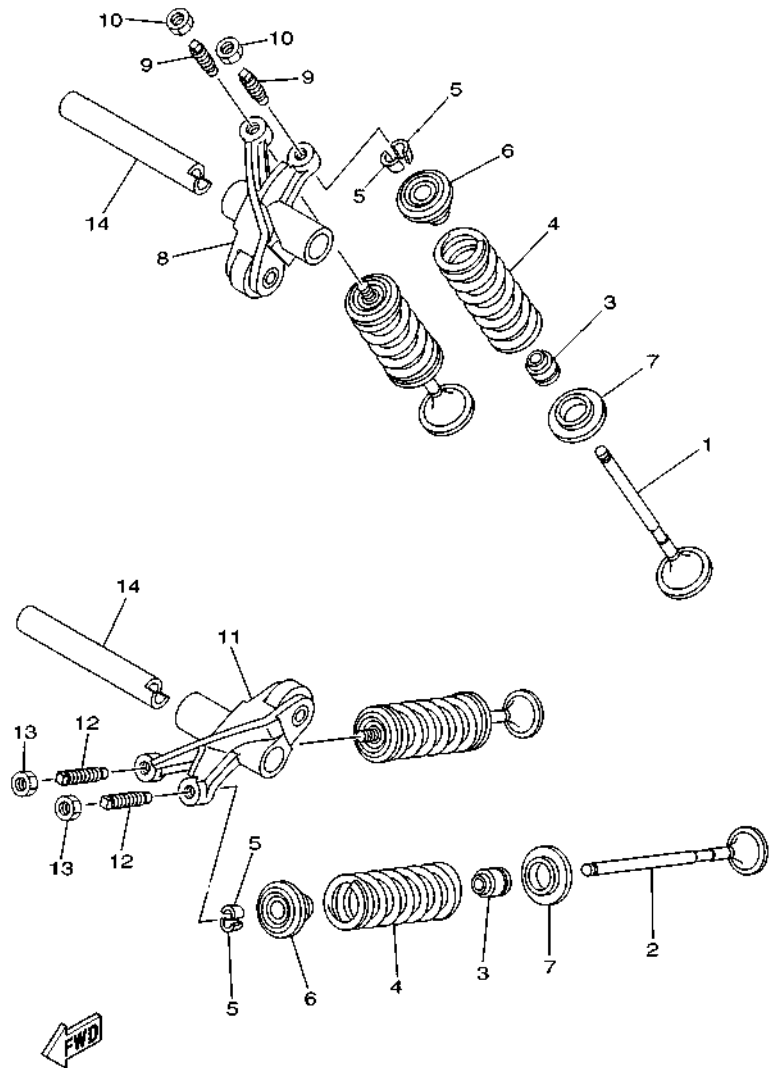
**FIG. 2 CRANKSHAFT & PISTON**



REF. NO.	PART NO.	DESCRIPTION	55D7				REMARKS
1	1S8-WE140-11	CRANKSHAFT ASSY	1				
2	1S8-WE141-00	.CRANK SUB ASSY 1	1				
3	1S8-11681-01	.PIN, CRANK 1	1				
4	93310-528X7	.BEARING	1				
5	1S8-E1651-00	.ROD, CONNECTING	1				
6	1S8-E1422-00	.CRANK 2	1				
7	93306-305X7	BEARING	1				
8	90280-03017	KEY, WOODRUFF	1				
9	2S6-E1631-21	PISTON (STD)	1				
10	1S8-11633-01	PIN, PISTON	1				
11	93450-16115	CIRCLIP	2				
12	50C-E1603-00	PISTON RING SET (STD)	1				

  
1S71460-E020

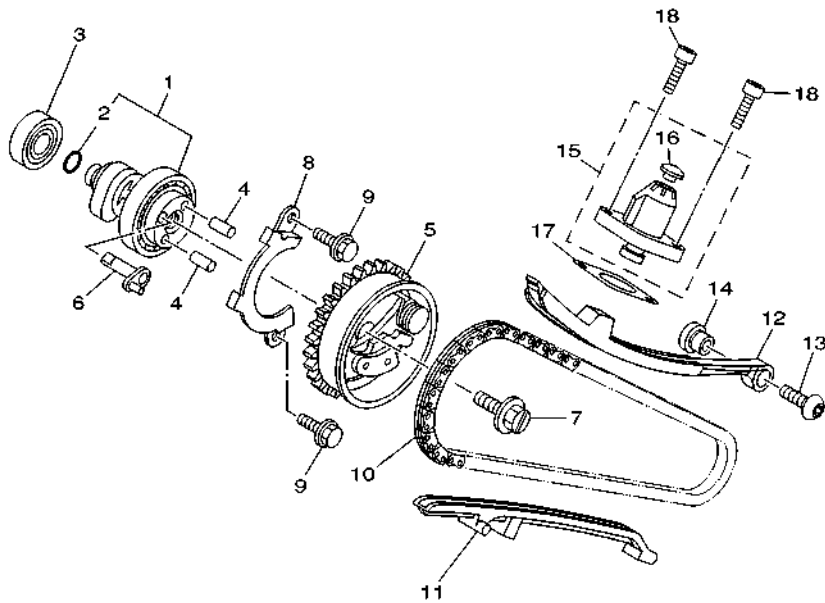
**FIG. 3 VALVE**



5YP1431-D030

REF. NO.	PART NO.	DESCRIPTION	55D7				REMARKS
1	2PV-E2111-00	VALVE, INTAKE	2				
2	2PV-E2121-00	VALVE, EXHAUST	2				
3	5YP-E2119-00	SEAL, VALVE STEM	4				
4	5YP-E2113-00	SPRING, VALVE INNER	4				
5	1WG-12118-00	LOCK, VALVE SPRING RETAINER	8				
6	5YP-12117-00	RETAINER, VALVE SPRING	4				
7	5YP-E2126-00	SEAT, VALVE SPRING 2	4				
8	5YP-E2151-00	ARM, VALVE ROCKER	1				
9	5YP-E2159-00	SCREW, VALVE ADJUSTING	2				
10	90170-05302	NUT	2				
11	5YP-E2161-00	ARM, VALVE ROCKER 2	1				
12	5YP-E2159-00	SCREW, VALVE ADJUSTING	2				
13	90170-05302	NUT	2				
14	1S8-E2156-00	SHAFT, ROCKER 2	2				



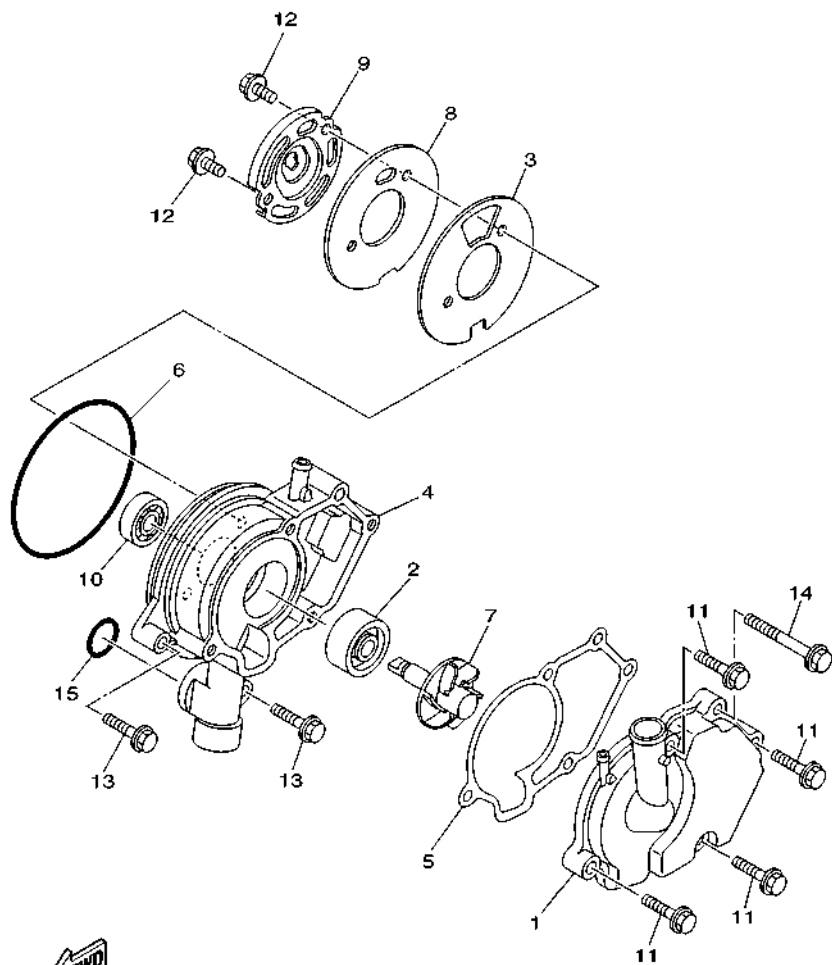


**FIG. 4 CAMSHAFT & CHAIN**

REF. NO.	PART NO.	DESCRIPTION	55D7				REMARKS
1	21S-E2170-01	CAMSHAFT ASSY 1	1				
2	93210-09805	.O-RING	1				
3	93306-001X2	BEARING	1				
4	93605-06002	PIN, DOWEL	2				
5	1B9-E2280-02	DECOMPRESSION ASSY	1				
6	5YP-E2288-00	CAM, DECOMPRESSION	1				
7	5YP-E2157-00	BOLT	1				
8	1S8-E111F-00	PLATE	1				
9	95027-06010	BOLT, FLANGE	2				
10	94568-A8096	CHAIN	1				
11	1S8-E2231-00	GUIDE, STOPPER 1	1				
12	5YP-E2241-00	GUIDE, STOPPER 2	1				
13	90149-06829	SCREW	1				
14	1S8-E5598-00	COLLAR	1				
15	5MX-E2210-00	TENSIONER ASSY, CAM CHAIN	1				
16	5MX-E2222-00	.PLUG	1				
17	1S8-E2213-01	GASKET, TENSIONER CASE	1				
18	91317-06016	BOLT,HEX.SOCKET HEAD	2				

  
 55D1440-K040

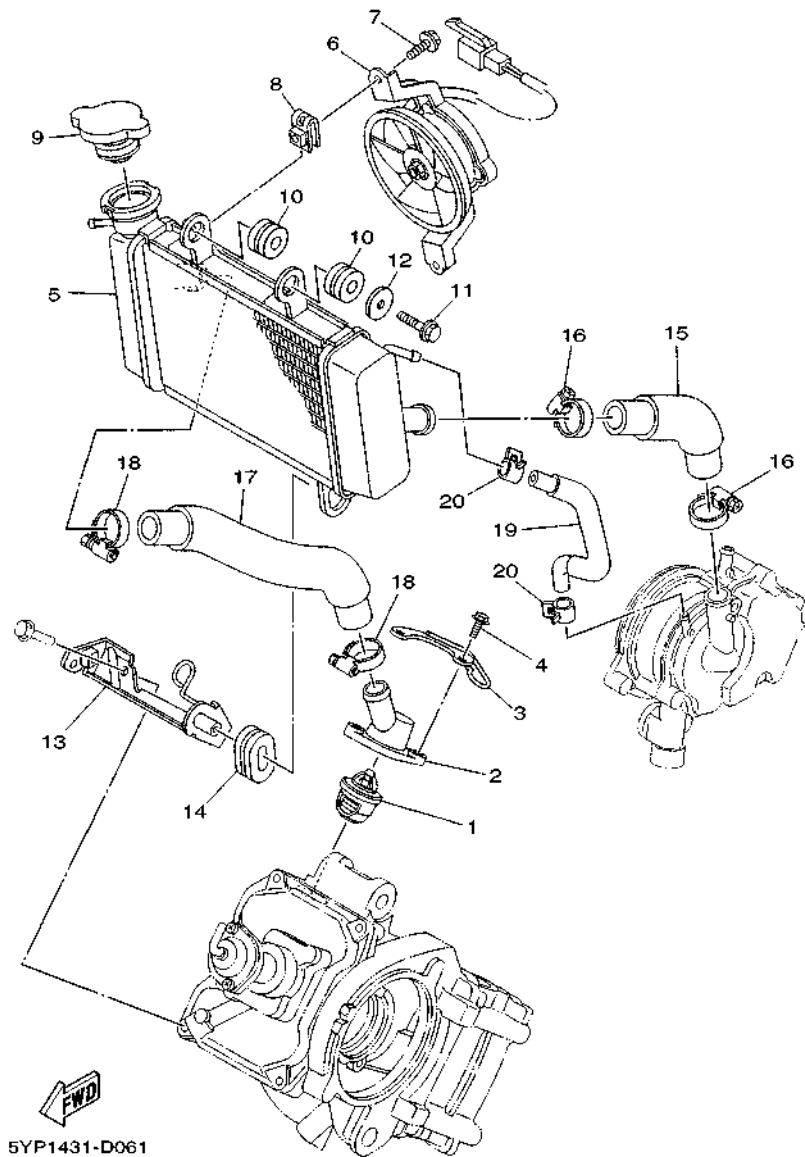
**FIG. 5 WATER PUMP**



**FWD**  
50C1460-K050

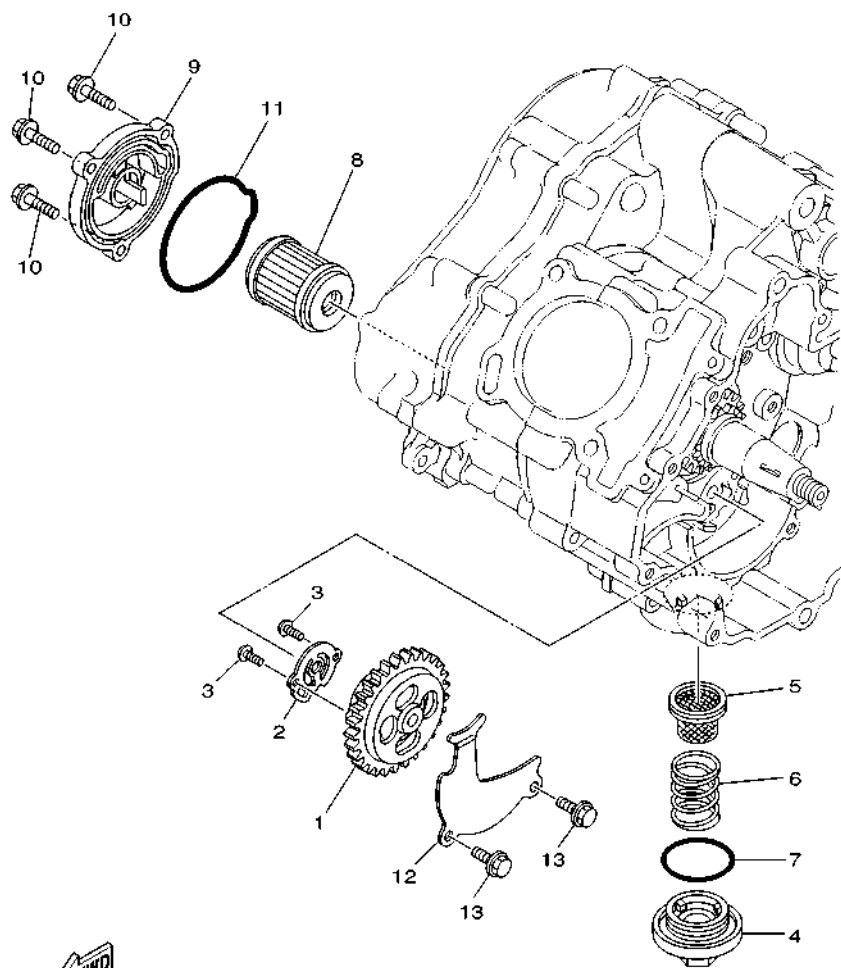
REF. NO.	PART NO.	DESCRIPTION	55D7				REMARKS
1	1S7-E2422-00	COVER, HOUSING	1				
2	93103-10801	OIL SEAL	1				
3	50C-E2428-00	GASKET, HOUSING COVER 2	1				
4	1S7-E1185-01	COVER, CYLINDER HEAD SIDE 3	1				
5	1S7-E1196-00	GASKET, CYLINDER HEAD SIDE	1				
6	93210-84801	O-RING	1				
7	1S7-E2450-00	IMPELLER SHAFT ASSY	1				
8	50C-E1951-00	PLATE	1				
9	1S7-E1952-01	PLATE	1				
10	93306-000Y3	BEARING	1				
11	95027-06025	BOLT, FLANGE	4				
12	95027-06012	BOLT, FLANGE	2				
13	95027-06025	BOLT, FLANGE	2				
14	95027-06050	BOLT, FLANGE	1				
15	93210-19809	O-RING	1				

**FIG. 6 RADIATOR & HOSE**



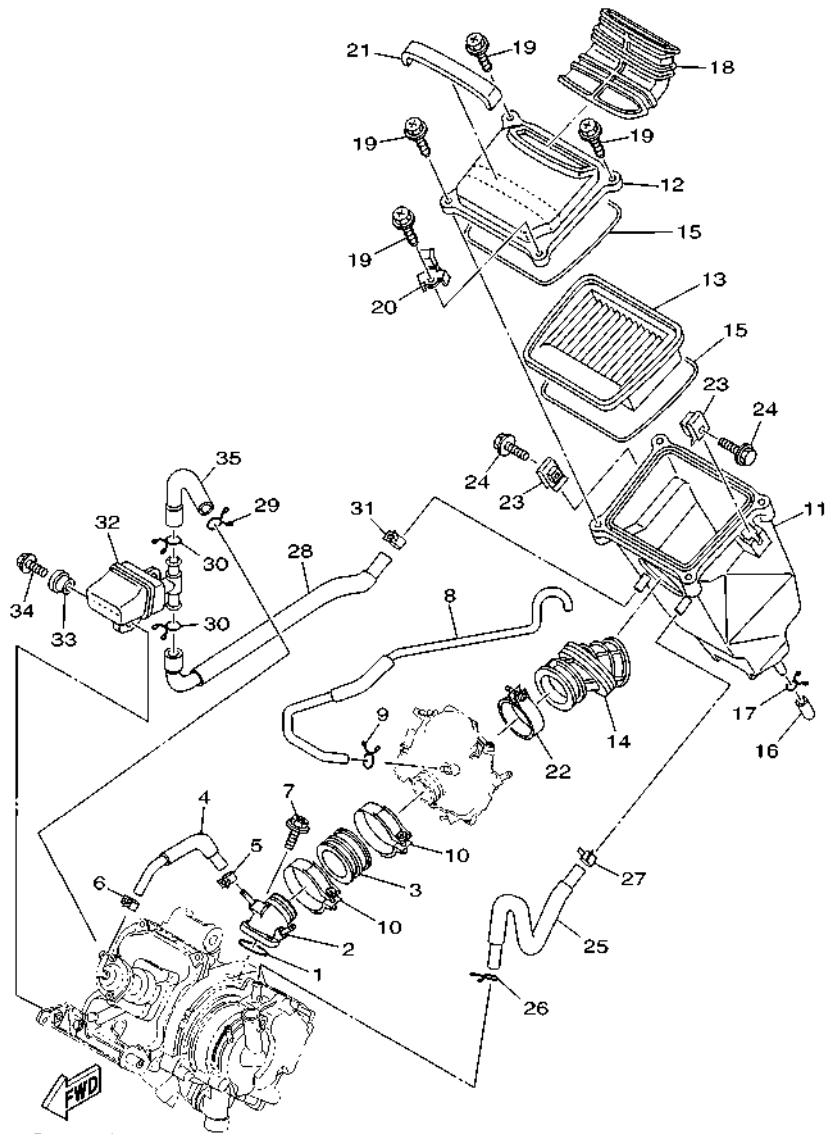
REF. NO.	PART NO.	DESCRIPTION	55D7				REMARKS
1	5YP-12411-00	THERMOSTAT	1				
2	1S8-E2413-00	COVER, THERMOSTAT	1				
3	5YP-E2491-00	CLAMP 1	1				
4	90105-06848	BOLT, FLANGE	2				
5	5YP-E2461-00	RADIATOR COMP	1				
6	5YP-E2405-00	BLOWER ASSY	1				
7	5YP-E2675-00	BOLT, BLOWER HOLDING	2				
8	5YP-E2671-00	NUT 1	2				
9	5P0-E2590-00	CONDUCTION ASSY	1				
10	90480-15363	GROMMET	2				
11	95827-06016	BOLT, FLANGE	1				
12	90201-06069	WASHER, PLATE	1				
13	1S8-E2443-01	STAY	1				
14	90480-01803	GROMMET	1				
15	1S8-E2481-00	PIPE 1	1				
16	90450-27803	HOSE CLAMP ASSY	2				
17	1S8-E2482-00	PIPE 2	1				
18	90450-27803	HOSE CLAMP ASSY	2				
19	5YP-E2576-00	HOSE 1	1				
20	90467-10038	CLIP	2				

**FIG. 7 OIL PUMP**



**FWD**  
55D5440-R070

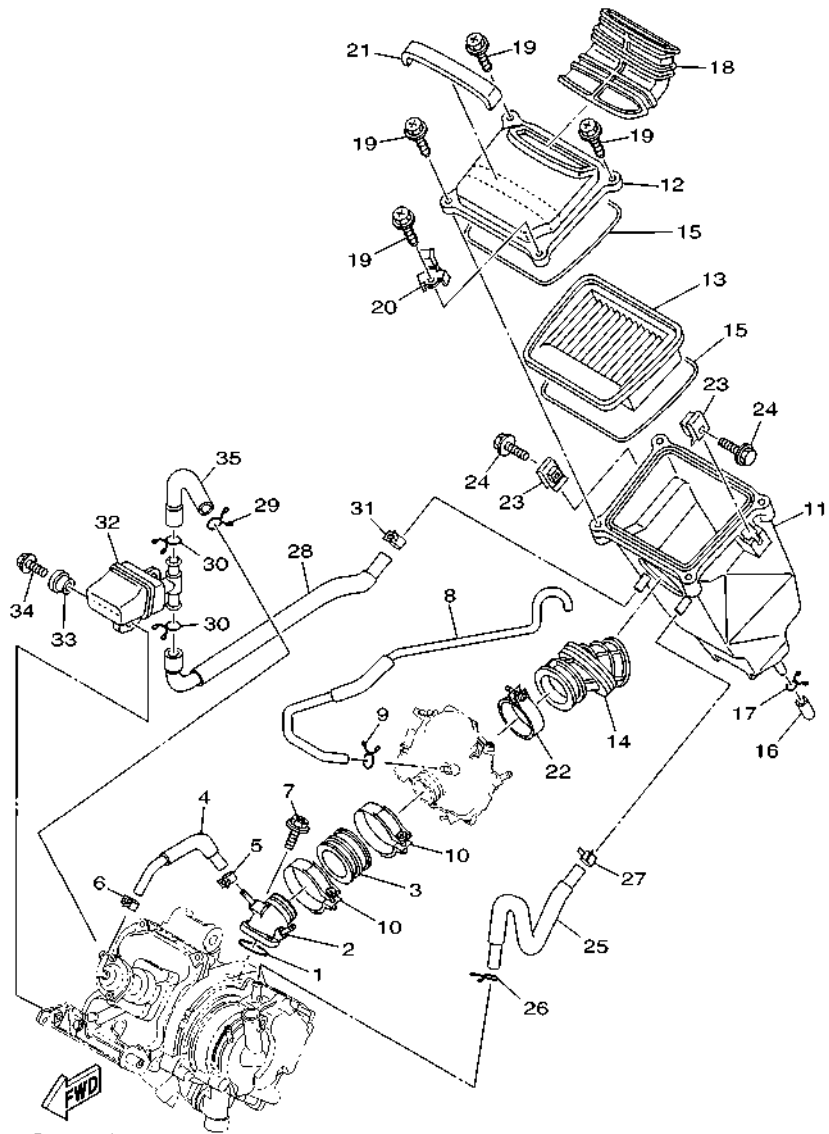
REF. NO.	PART NO.	DESCRIPTION	55D7				REMARKS
1	1S7-E3300-00	OIL PUMP ASSY	1				
2	1S8-E3329-00	GASKET, PUMP COVER	1				
3	92017-05025	BOLT, BUTTON HEAD	2				
4	1S8-E5351-00	PLUG, DRAIN	1				
5	1S8-E3411-00	STRAINER, OIL	1				
6	90501-18576	SPRING, COMPRESSION	1				
7	93210-34801	O-RING	1				
8	38B-E3440-00	ELEMENT ASSY, OIL CLEANER	1				
9	2S5-E3447-00	COVER, OIL ELEMENT	1				
10	9502L-06020	BOLT, FLANGE	3				
11	93210-59800	O-RING	1				
12	1S8-E3327-00	COVER, PUMP GEAR	1				
13	9502L-06012	BOLT, FLANGE	2				



55D1440-K080

FIG. 8 INTAKE

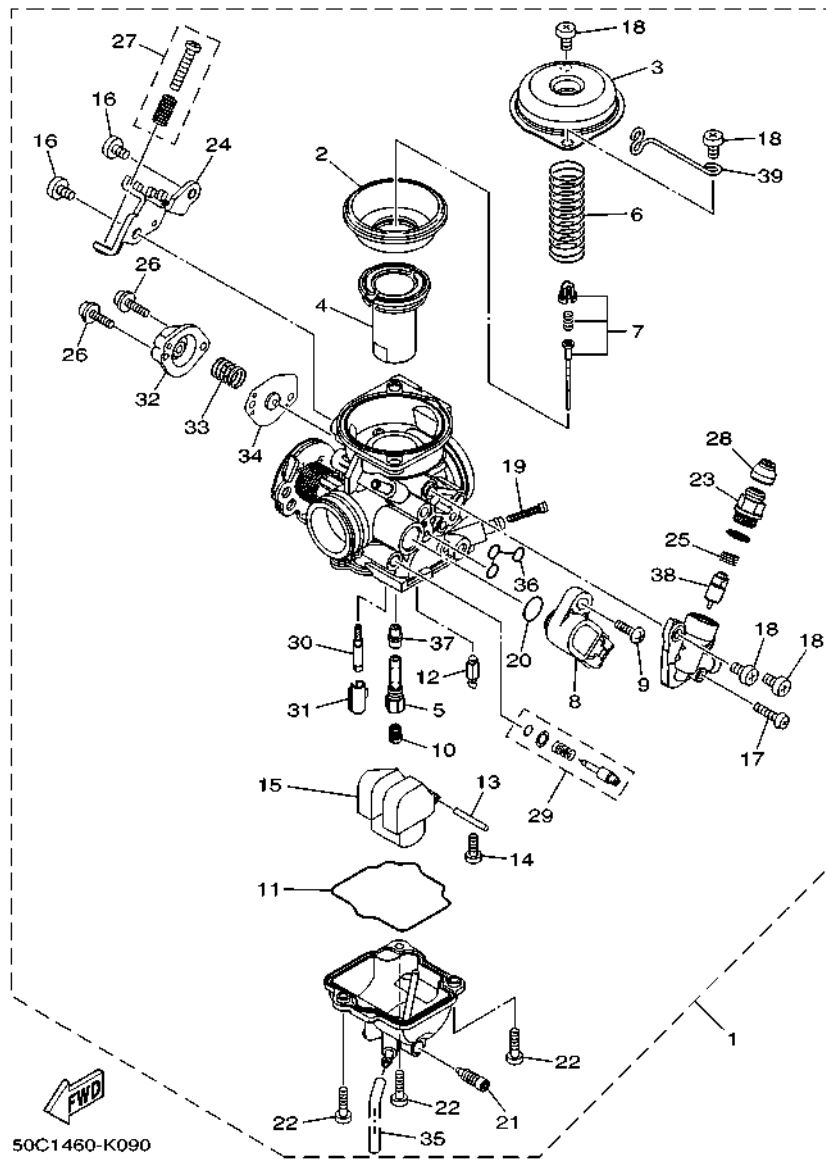
REF. NO.	PART NO.	DESCRIPTION	55D7				REMARKS
1	93210-32807	O-RING	1				
2	50C-E3536-00	JT. , CARBURETOR	1				
3	55P-E3586-00	JOINT, CARBURETOR 1	1				
4	1S7-E3542-00	HOSE, VACUUM SENSING 1	1				
5	90467-08801	CLIP	1				
6	90467-08801	CLIP	1				
7	90105-06061	BOLT, FLANGE	2				
8	55C-E4197-00	PIPE	1				
9	90467-07029	CLIP	1				
10	5MX-E3474-01	BAND	2				
11	50C-E4411-00	CASE, AIR CLEANER 1	1				
12	1S7-E4412-00	CAP, CLEANER CASE 1	1				
13	1S7-E4450-00	ELEMENT ASSY, AIR CLEANER	1				
14	50C-E4453-00	JOINT, AIR CLEANER 1	1				
15	1S7-E4452-00	SEAL	2				
16	5TL-E443E-00	PIPE, DRAIN	1				
17	90467-12800	CLIP	1				
18	1S7-E4437-00	DUCT	1				
19	90163-05803	SCREW, TAPPING	4				
20	90462-08814	CLAMP	1				
21	1S7-E4425-00	DAMPER 1	1				
22	5MX-E3575-01	BAND	1				
23	90183-06023	NUT, SPRING	2				
24	90119-06051	BOLT, WITH WASHER	2				
25	55P-E1166-00	PIPE, BREATHER 1	1				
26	90467-13858	CLIP	1				
27	90467-13064	CLIP	1				



55D1440-K080

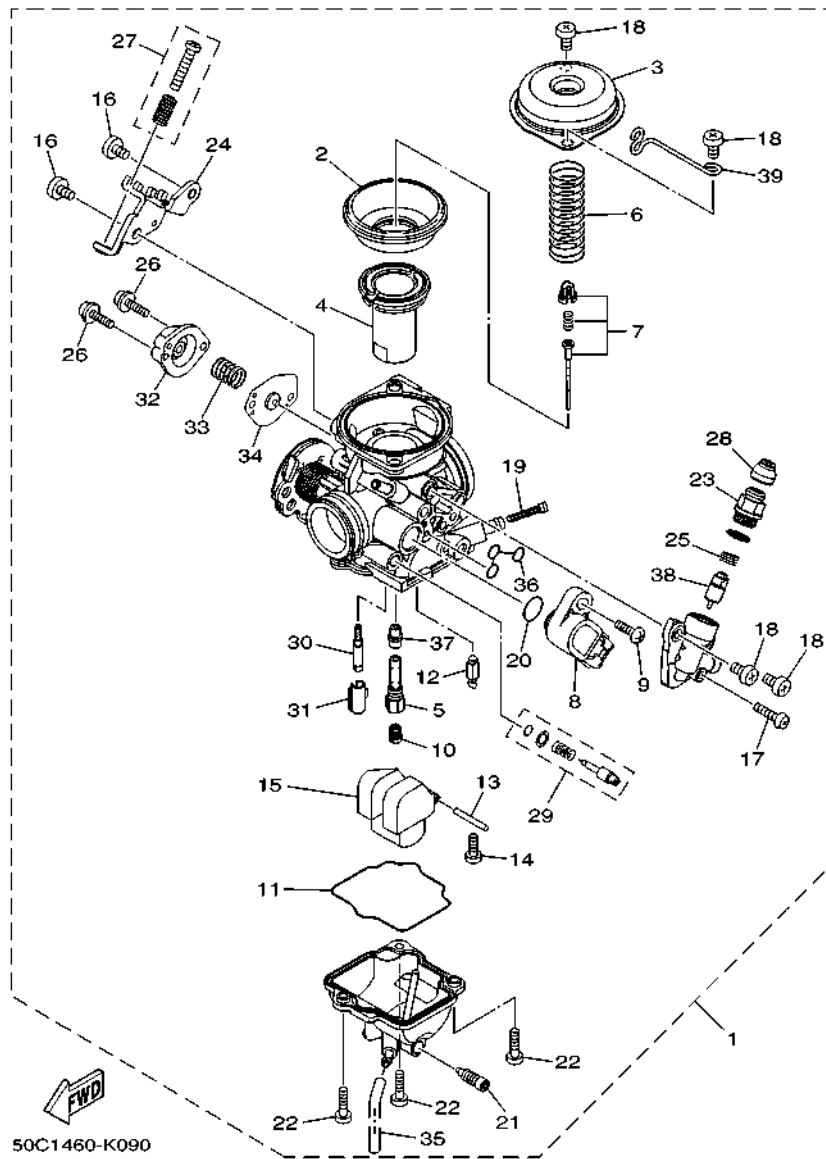
FIG. 8 INTAKE

REF. NO.	PART NO.	DESCRIPTION	55D7				REMARKS
28	55C-E4882-00	HOSE, BEND 2	1				
29	90467-15012	CLIP	1				
30	90467-15012	CLIP	2				
31	90467-14117	CLIP	1				
32	1S7-E4877-01	RESONATOR	1				
33	90387-068B0	COLLAR	1				
34	97027-06016	BOLT, HEXAGON	1				
35	5YP-E4881-00	HOSE, BEND 1	1				



**FIG. 9 CARBURETOR**

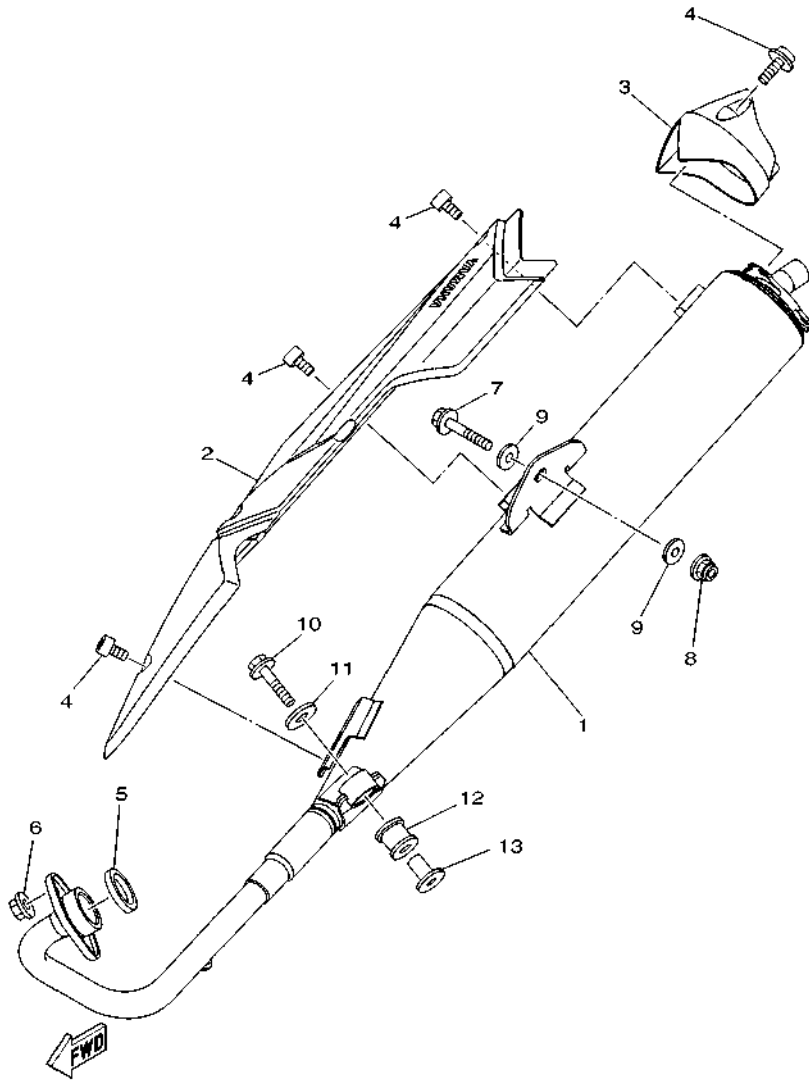
REF. NO.	PART NO.	DESCRIPTION	55D7	REMARKS
1	55D-E4901-10	CARBURETOR ASSY 1	1	
2	5LW-24411-00	.DIAPHRAGM	1	
3	5LW-14958-00	.COVER, DIAPHRAGM	1	
4	31S-14112-00	.VALVE, THROTTLE 1	1	
5	50C-14261-00	.HOLDER	1	
6	50C-14589-00	.SPRING	1	
7	55D-1490J-00	.NEEDLE SET	1	
8	18D-H5885-00	.THROTTLE SENSOR ASSY	1	
9	5YP-14429-00	.SCREW	1	
10	3G2-14231-23	.JET, MAIN (#115)	1	
11	5HK-14147-00	.O-RING	1	
12	5LW-14150-00	.NEEDLE ASSY	1	
13	353-14186-00	.PIN, FLOAT	1	
14	98507-04008	.SCREW, PAN HEAD	1	
15	5HK-14985-00	.FLOAT	1	
16	98507-05008	.SCREW, PAN HEAD	2	
17	98507-04018	.SCREW, PAN HEAD	1	
18	98507-05010	.SCREW, PAN HEAD	4	
19	5LW-14994-00	.NET, FILTER	1	
20	5YP-14561-00	.O-RING	1	
21	5MP-14191-00	.PLUG, DRAIN	1	
22	98507-04014	.SCREW, PAN HEAD	3	
23	3RW-14174-00	.CAP, PLUNGER	1	
24	50C-14995-00	.BRACKET	1	
25	509-14135-00	.COIL, SPRING	1	
26	97607-04114	.SCREW, WITH WASHER	2	
27	5LW-14103-00	.THROTTLE SCREW SET	1	



**FIG. 9 CARBURETOR**

REF. NO.	PART NO.	DESCRIPTION	55D7	REMARKS
28	22F-14173-00	.COVER, PLUNGER CAP	1	
29	50C-14105-00	.PILOT SCREW SET	1	
30	5P0-14142-15	.JET, PILOT (# 15)	1	
31	4JG-14261-00	.HOLDER	1	
32	33S-14280-00	.COVER, CARBURETOR	1	
33	5HK-14275-00	.SPRING	1	
34	5AP-14940-00	.DIAPHRAGM ASSY	1	
35	5FC-14149-00	.PIPE	1	
36	5LW-14147-00	.O-RING	1	
37	5P0-14141-13	.NOZZLE, MAIN	1	
38	5LW-14171-10	.PLUNGER, STARTER	1	
39	50C-14137-00	.CLIP	1	



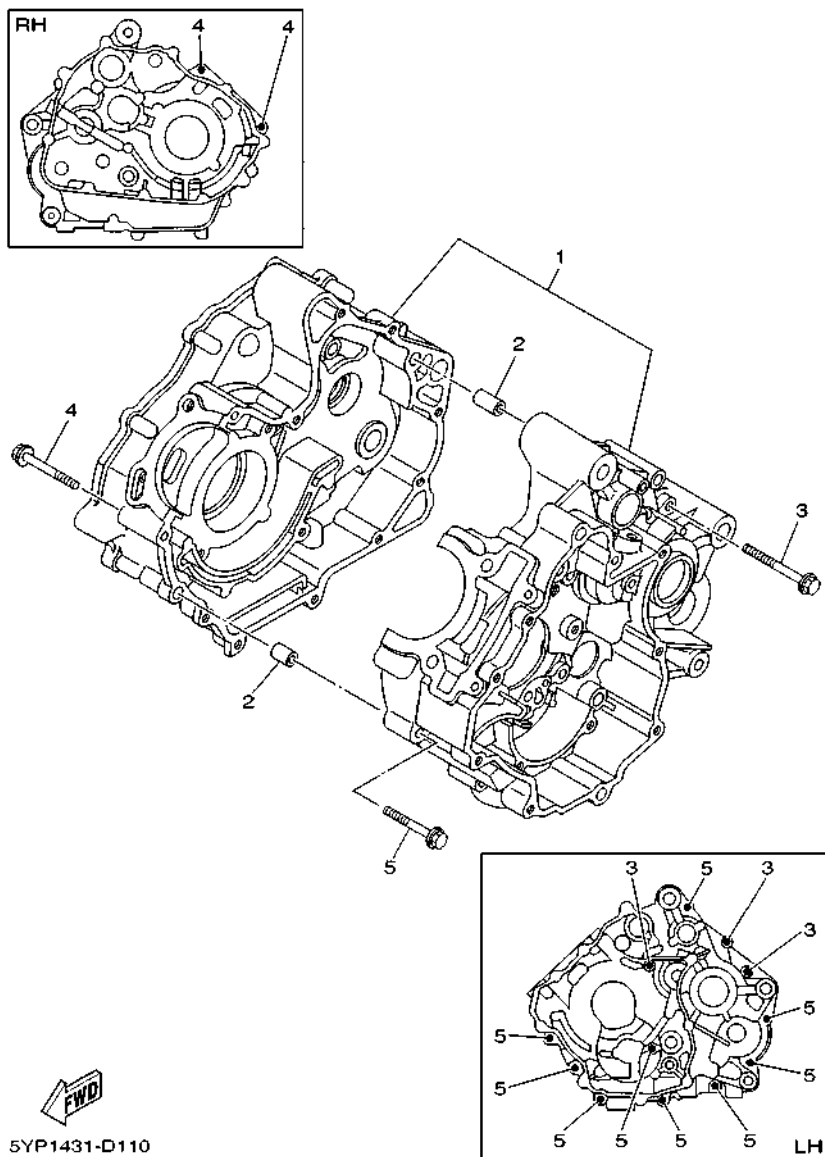


55D4440-S100

FIG. 10 EXHAUST

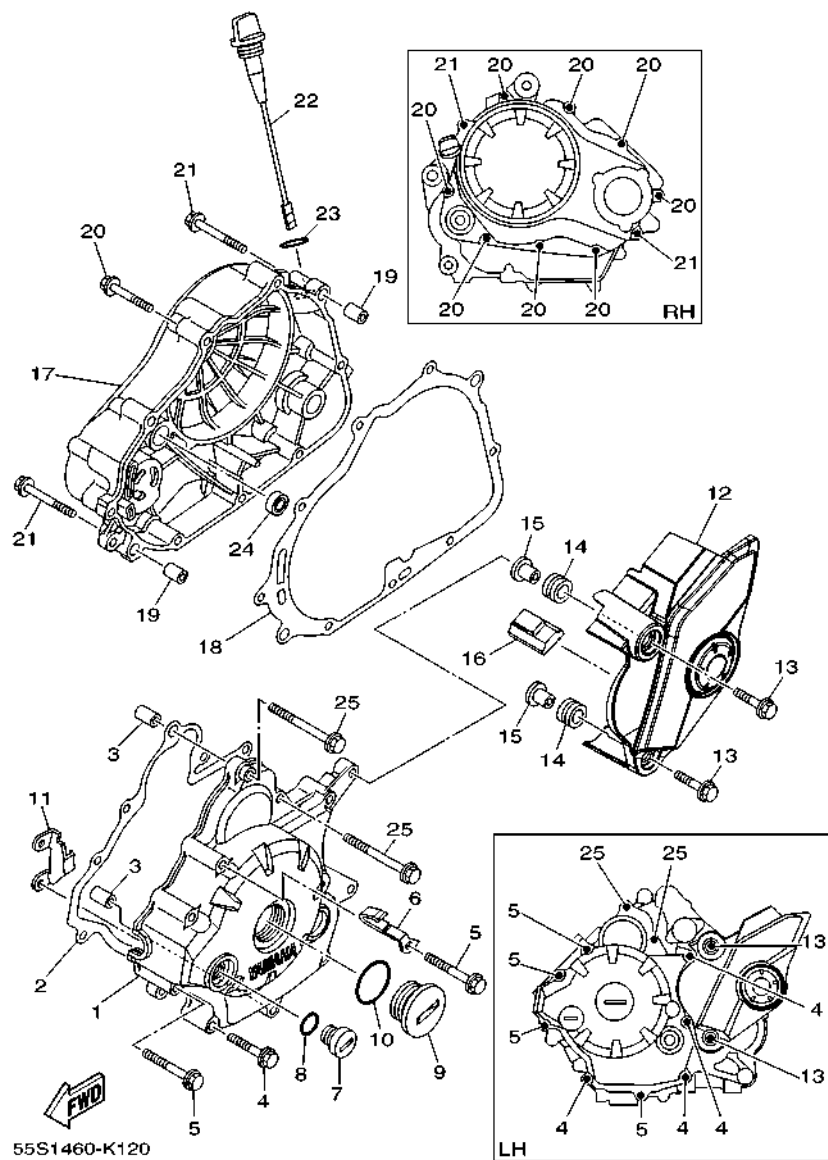
REF. NO.	PART NO.	DESCRIPTION	55D7				REMARKS
1	55D-E4703-10	MUFFLER COMP. 1	1				
2	55D-E4718-10	PROTECTOR, MUFFLER 1	1				
3	55D-E4799-10	CAP	1				
4	90111-06807	BOLT,HEX. SOCKET BUTTON	6				
5	1S8-E4613-00	GASKET, EXHAUST PIPE	1				
6	95707-08500	NUT, FLANGE	2				
7	95827-10045	BOLT, FLANGE	1				
8	95707-10500	NUT, FLANGE	1				
9	90201-10141	WASHER, PLATE	2				
10	95807-08035	BOLT, FLANGE	1				
11	90201-08612	WASHER, PLATE	1				
12	29B-E4747-00	DAMPER, MUFFLER	1				
13	90387-08822	COLLAR	1				

FIG. 11 CRANKCASE



5YP1431-D110

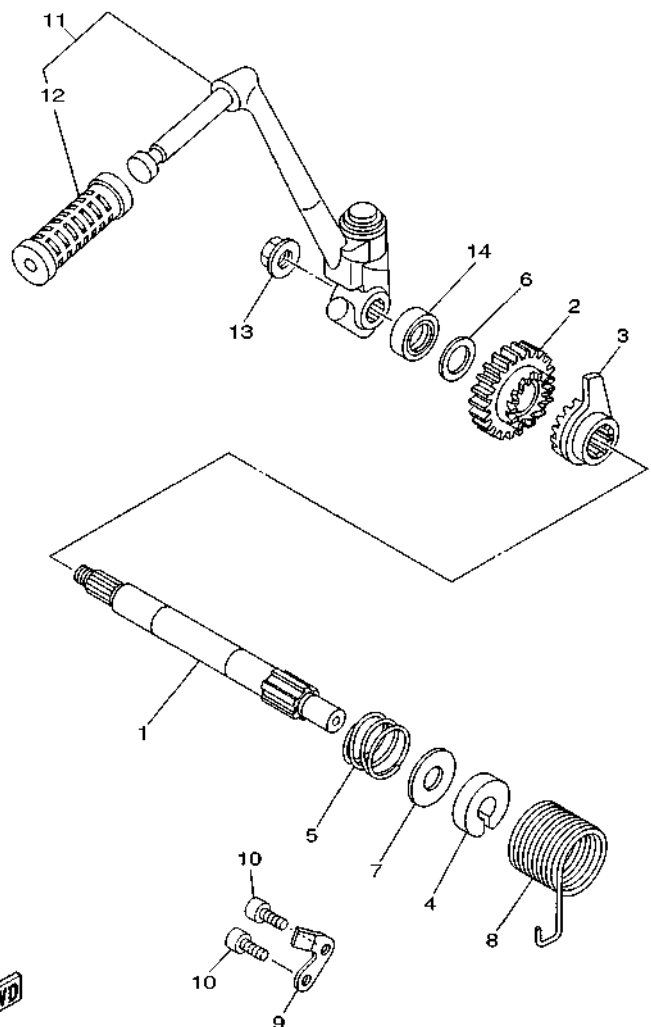
REF. NO.	PART NO.	DESCRIPTION	55D7	REMARKS
1	1S8-E5150-00	CRANKCASE ASSY	1	
2	99530-10114	PIN, DOWEL	2	
3	9502L-06060	BOLT, FLANGE	3	
4	9502L-06050	BOLT, FLANGE	2	
5	9502L-06045	BOLT, FLANGE	9	



**FIG. 12 CRANKCASE COVER 1**

REF. NO.	PART NO.	DESCRIPTION	55D7				REMARKS
1	55D-E5411-00	COVER, CRANKCASE 1	1				
2	55D-E5451-00	GASKET, CRANKCASE COVER 1	1				
3	99530-10114	PIN, DOWEL	2				
4	9502L-06040	BOLT, FLANGE	4				
5	9502L-06050	BOLT, FLANGE	4				
6	90462-08817	CLAMP	1				
7	90340-14824	PLUG, STRAIGHT SCREW	1				
8	93210-14899	O-RING	1				
9	90340-32823	PLUG, STRAIGHT SCREW	1				
10	93210-32803	O-RING	1				
11	5YP-E5113-00	PLATE	1				
12	55D-E5418-00	COVER, CHAIN CASE	1				
13	95807-06025	BOLT, FLANGE	2				
14	90480-13808	GROMMET	2				
15	90387-06063	COLLAR	2				
16	5YP-E5377-00	GUIDE, INLET	1				
17	55D-E5421-00	COVER, CRANKCASE 2	1				
18	55D-E5461-00	GASKET, CRANKCASE COVER 2	1				
19	99530-10114	PIN, DOWEL	2				
20	9502L-06040	BOLT, FLANGE	8				
21	9502L-06050	BOLT, FLANGE	2				
22	1S8-E5362-00	PLUG, OIL LEVEL	1				
23	93210-198F0	O-RING	1				
24	93101-10841	OIL SEAL	1				
25	9502L-06060	BOLT, FLANGE	2				

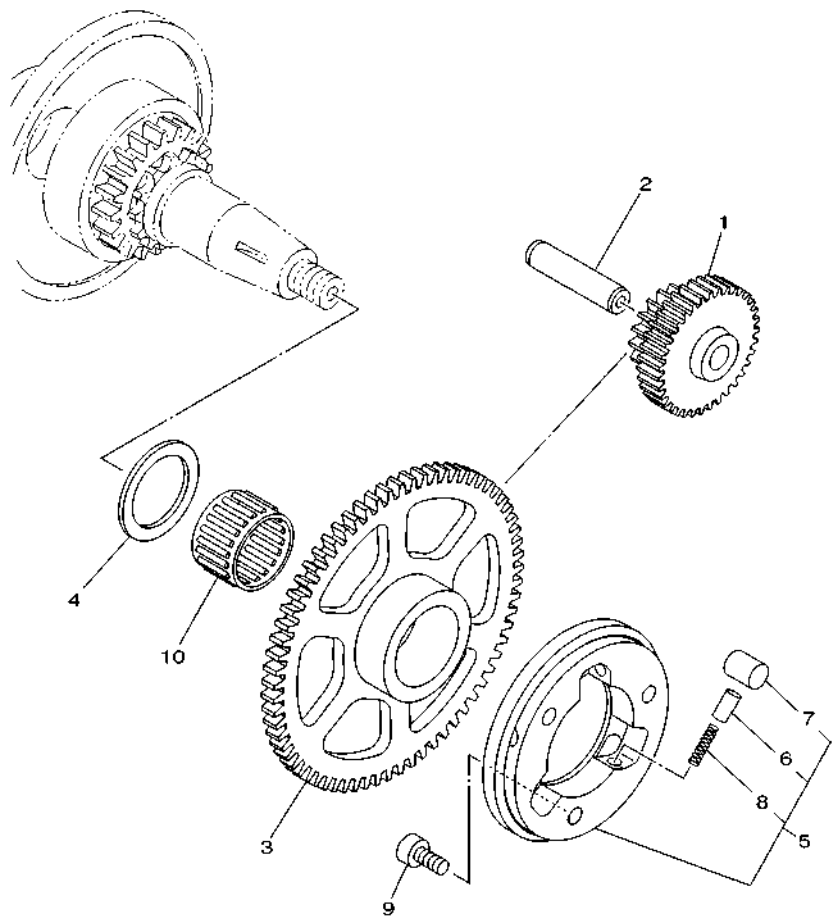
**FIG. 13 STARTER**



5YP1431-D130

REF. NO.	PART NO.	DESCRIPTION	55D7				REMARKS
1	1S9-E5661-00	AXLE, KICK	1				
2	5YP-E5641-00	GEAR, KICK	1				
3	5YP-E5671-00	WHEEL, RATCHET	1				
4	5YP-E5664-00	GUIDE, SPRING	1				
5	5YP-E5767-00	SPRING	1				
6	90201-16803	WASHER, PLATE	1				
7	5YP-E5696-00	WASHER 2	1				
8	5YP-E5555-00	SPRING, RETURN	1				
9	5YP-E5674-00	GUID, RATCHET WHEEL	1				
10	91317-06016	BOLT,HEX.SOCKET HEAD	2				
11	1S8-E5620-00	KICK CRANK ASSY	1				
12	2N9-E5618-00	.COVER, KICK LEVER	1				
13	90179-10017	NUT	1				
14	93102-16800	OIL SEAL	1				

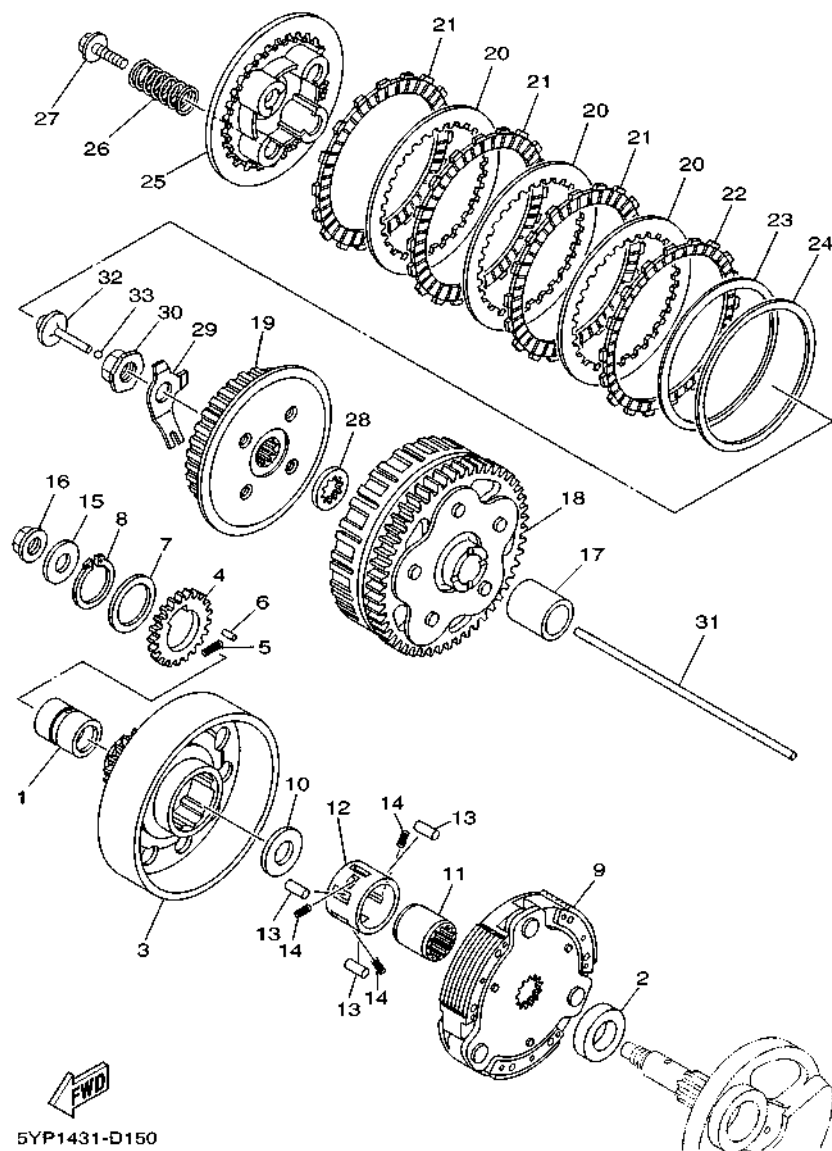
**FIG. 14 STARTER CLUTCH**



 55D2440-L140

REF. NO.	PART NO.	DESCRIPTION	55D7	REMARKS
1	5YP-E5514-00	GEAR 2	1	
2	1S8-E5521-00	SHAFT 1	1	
3	55D-E5524-00	WHEEL, STARTER	1	
4	90201-25290	WASHER, PLATE	1	
5	1ST-E5580-00	STARTER CLUTCH OUTER ASSY	1	
6	1ST-E5583-00	.CAP, STARTER CLUTCH SPRING	3	
7	1ST-E5614-00	.PIN, DOWEL	3	
8	90501-030A0	.SPRING, COMPRESSION	3	
9	91317-06014	BOLT, HEX. SOCKET HEAD	3	
10	93310-325X1	BEARING	1	

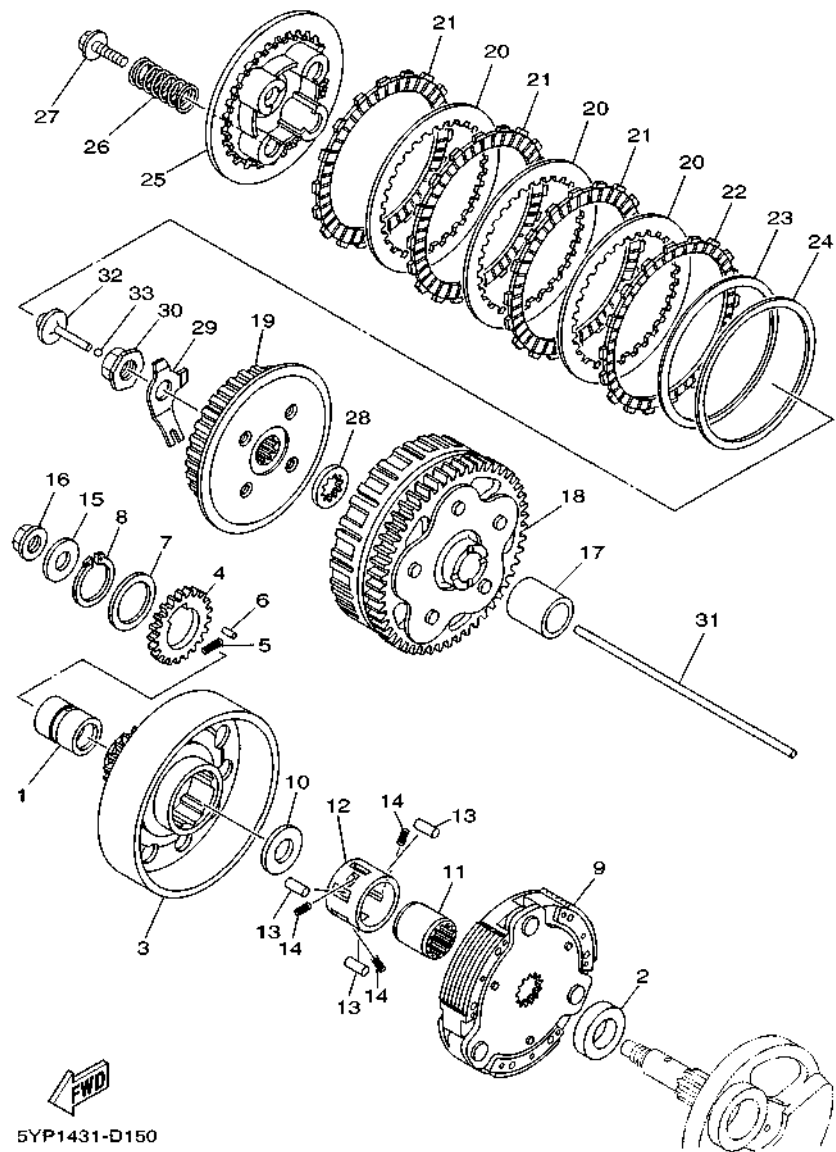
FIG. 15 CLUTCH



5YP1431-D150

REF. NO.	PART NO.	DESCRIPTION	55D7				REMARKS
1	5YP-E6116-00	COLLAR 1	1				
2	5YP-E6182-00	SPACER 2	1				
3	5YP-E6611-00	CLUTCH HOUSING COMP.	1				
4	5YP-E6131-00	GEAR, PRIMARY DRIVE 2	1				
5	5YP-E6539-00	SPRING	1				
6	93602-08810	PIN, DOWEL	1				
7	5YP-E6144-00	WASHER	1				
8	99009-28400	CIRCLIP	1				
9	5YP-E6620-00	CLUTCH CARRIER ASSY	1				
10	90201-167P7	WASHER, PLATE	1				
11	5YP-E6512-00	BOSS, CLUTCH HOUSING	1				
12	5YP-E6586-00	CAGE	1				
13	5YP-E6143-00	PIN, ROLLER	3				
14	90501-04801	SPRING, COMPRESSION	3				
15	90201-12019	WASHER, PLATE	1				
16	90179-12659	NUT	1				
17	1S8-E6181-00	SPACER 1	1				
18	5YP-E6150-00	PRIMARY DRIVEN GEAR COMP.	1				
19	5YP-E6371-00	BOSS, CLUTCH	1				
20	5YP-E6324-00	PLATE, CLUTCH 1	3				
21	5YP-E6321-00	PLATE, FRICTION	3				
22	5YP-E6331-00	PLATE, FRICTION 2	1				
23	5YP-E6383-00	SPRING, CUSHION	1				
24	5YP-E6384-00	PLATE, SEAT	1				
25	5YP-E6351-00	PLATE, PRESSURE 1	1				
26	5YP-E6333-00	SPRING, CLUTCH 1	4				
27	5YP-E6777-00	BOLT	4				

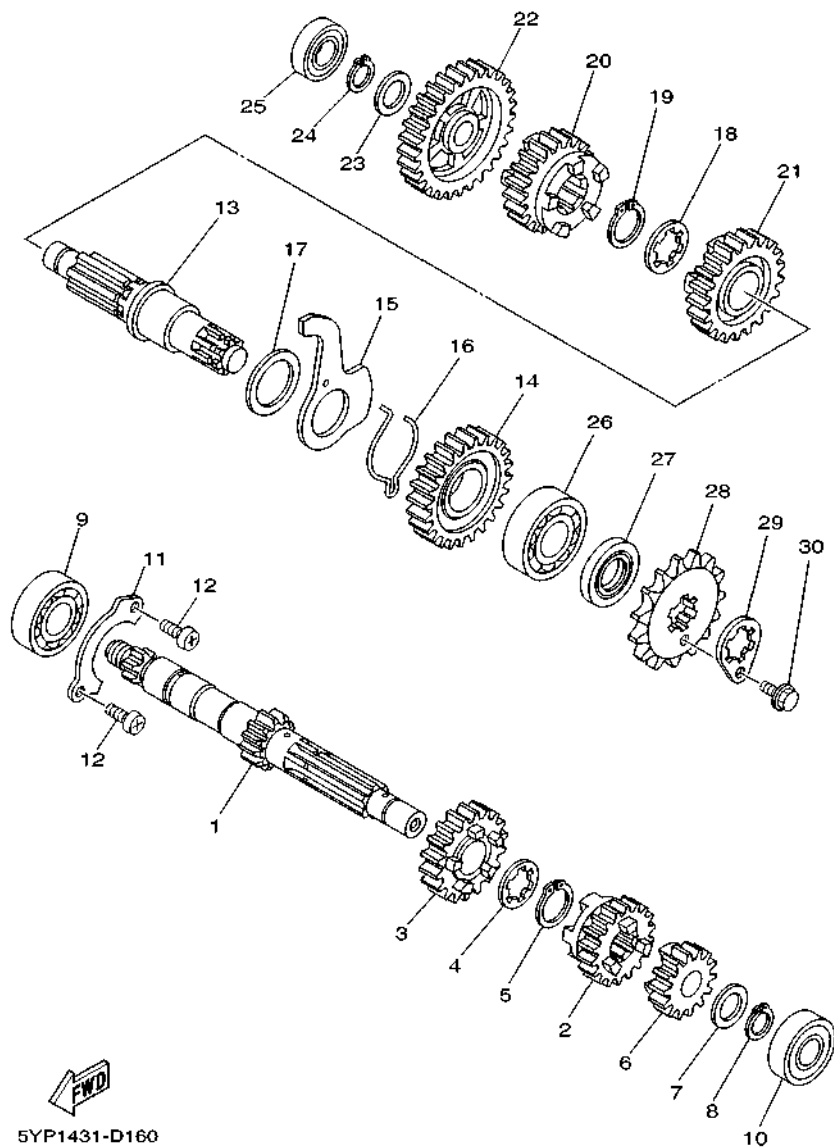
**FIG. 15 CLUTCH**



5YP1431-D150

REF. NO.	PART NO.	DESCRIPTION	55D7				REMARKS
28	5YP-E6628-00	WASHER	1				
29	1S8-E6135-00	WASHER, LOCK	1				
30	90179-14001	NUT	1				
31	5YP-E6357-00	ROD, PUSH 2	1				
32	5YP-E6356-00	ROD, PUSH 1	1				
33	93503-16807	BALL	1				

**FIG. 16 TRANSMISSION**

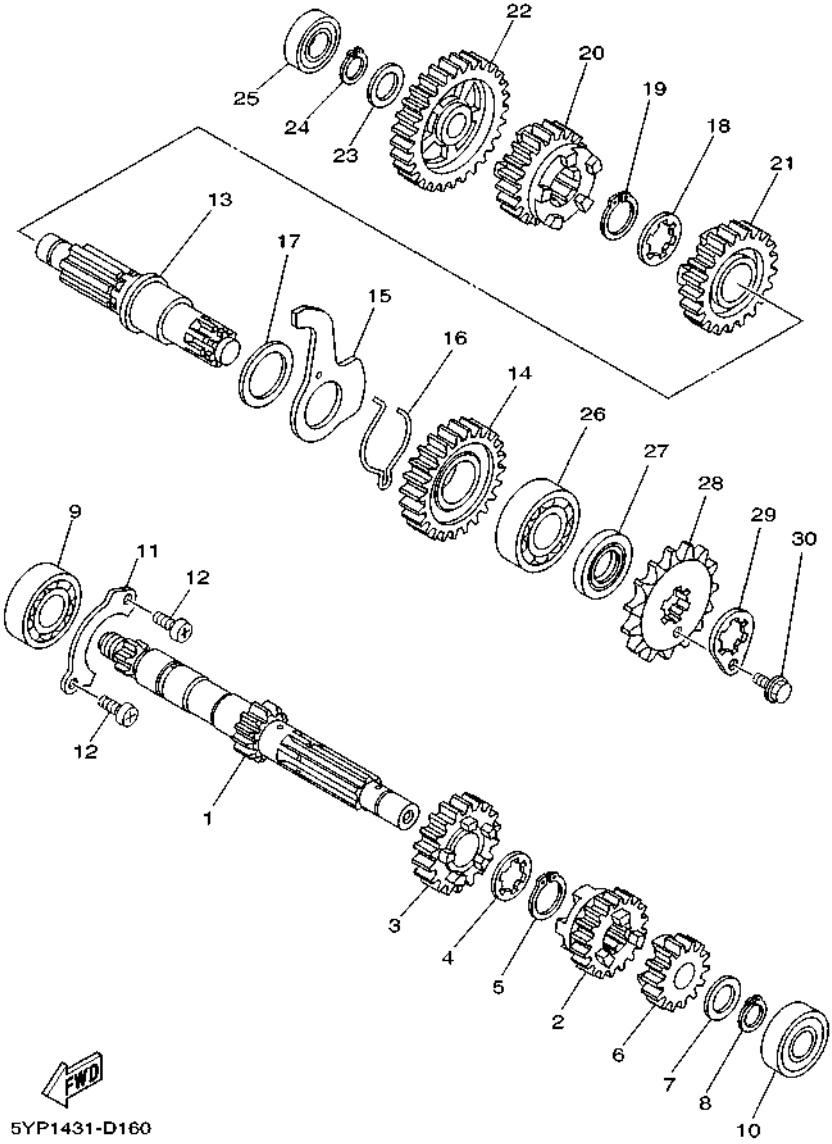


5YP1431-D160

REF. NO.	PART NO.	DESCRIPTION	55D7				REMARKS
1	5YP-E7411-00	AXLE, MAIN (12T)	1				
2	5YP-E7131-00	GEAR, 3RD PINION (17T)	1				
3	5YP-E7141-00	GEAR, 4TH PINION (22T)	1				
4	90209-17285	WASHER	1				
5	93410-20809	CIRCLIP	1				
6	5YP-E7121-00	GEAR, 2ND PINION (16T)	1				
7	90201-15700	WASHER, PLATE	1				
8	99009-15400	CIRCLIP	1				
9	93306-004XR	BEARING	1				
10	93306-252X1	BEARING	1				
11	1S8-E7471-00	PLATE, COVER	1				
12	98517-06012	SCREW, PAN HEAD	2				
13	5YP-E7421-00	AXLE, DRIVE	1				
14	5YP-E7221-00	GEAR, 2ND WHEEL (30T)	1				
15	5YP-E8561-00	PLATE, SIDE 1	1				
16	5TN-E8545-00	SPRING	1				
17	90201-26802	WASHER, PLATE	1				
18	90209-18208	WASHER	1				
19	93410-22820	CIRCLIP	1				
20	5YP-E7241-00	GEAR, 4TH WHEEL (23T)	1				
21	5YP-E7231-00	GEAR, 3RD WHEEL (23T)	1				
22	5YP-E7211-00	GEAR, 1ST WHEEL (34T)	1				
23	90201-15700	WASHER, PLATE	1				
24	99009-15400	CIRCLIP	1				
25	93306-002X8	BEARING	1				
26	93306-204YL	BEARING	1				
27	93102-20881	OIL SEAL	1				

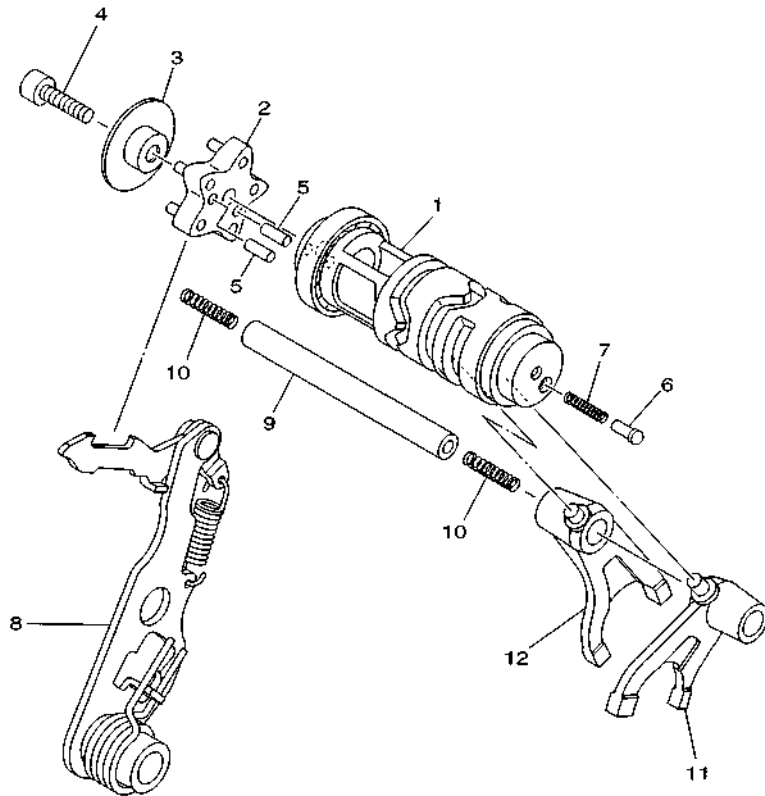


**FIG. 16 TRANSMISSION**



5YP1431-D160

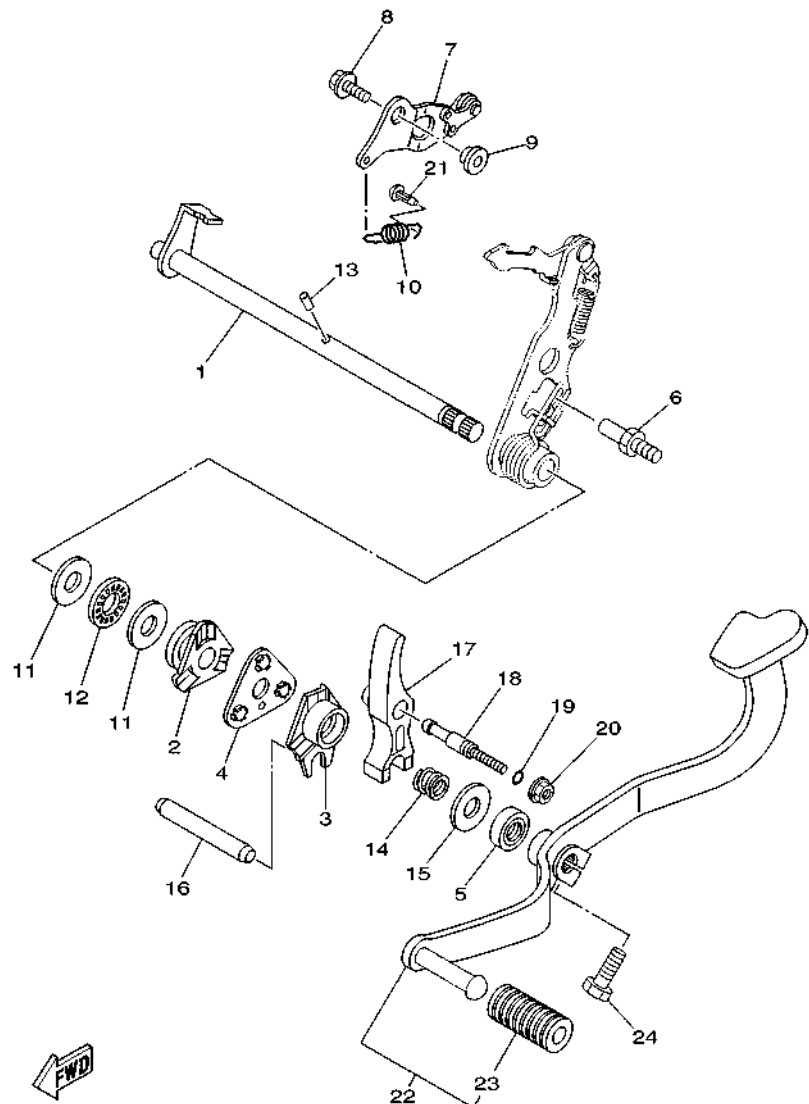
REF. NO.	PART NO.	DESCRIPTION	55D7				REMARKS
28	93822-15811	SPROCKET, DRIVE (15T)	1				
29	1S8-E7456-00	HOLDER, SPROCKET	1				
30	95027-06010	BOLT, FLANGE	1				



5YP1431-D170

**FIG. 17 SHIFT CAM & FORK**

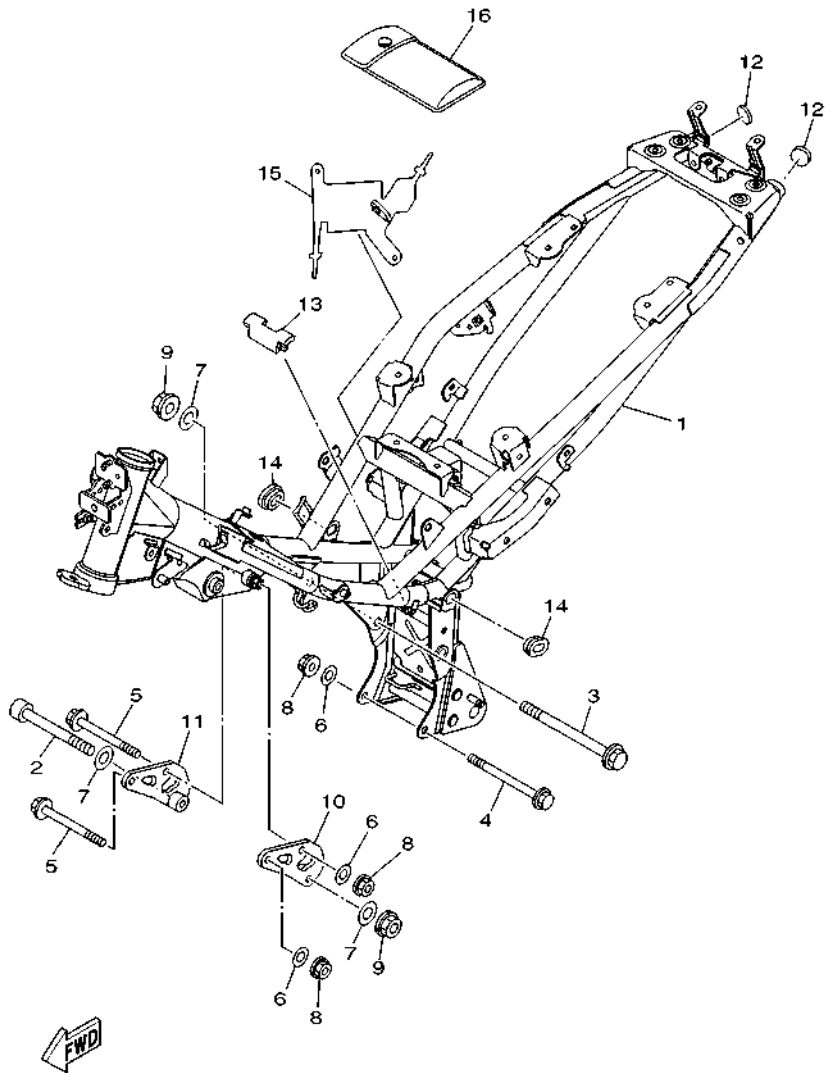
REF. NO.	PART NO.	DESCRIPTION	55D7				REMARKS
1	5YP-E8540-00	SHIFT CAM ASSY	1				
2	5YP-E8185-00	SEGMENT	1				
3	5YP-E8549-00	STOPPER	1				
4	91317-06025	BOLT,HEX.SOCKET HEAD	1				
5	93604-12831	PIN, DOWEL	2				
6	4TT-E8542-00	POINT, NEUTRAL	1				
7	90501-06022	SPRING, COMPRESSION	1				
8	5YP-E8120-00	SHIFT LEVER ASSY	1				
9	1S8-E8531-00	BAR, SHIFT FORK GUIDE 1	1				
10	90501-06800	SPRING, COMPRESSION	2				
11	5YP-E8511-00	FORK, SHIFT 1	1				
12	5YP-E8512-00	FORK, SHIFT 2	1				



5YP1431-D180

FIG. 18 SHIFT SHAFT

REF. NO.	PART NO.	DESCRIPTION	55D7	REMARKS
1	5YP-E8101-00	SHIFT SHAFT ASSY	1	
2	5YP-E8179-00	GUIDE	1	
3	5YP-E8172-00	GUIDE, SHIFT	1	
4	5YP-E8181-00	HOLDER, PAWL	1	
5	93102-12883	OIL SEAL	1	
6	5YP-E8127-00	STOPPER, SCREW	1	
7	5YP-E8140-00	STOPPER LEVER ASSY	1	
8	95827-06014	BOLT, FLANGE	1	
9	1S7-E8175-00	SPACER	1	
10	5YP-E8337-00	SPRING	1	
11	90201-12817	WASHER, PLATE	2	
12	93340-212Y2	BEARING	1	
13	93604-10837	PIN, DOWEL	1	
14	90501-125E9	SPRING, COMPRESSION	1	
15	90201-126A7	WASHER, PLATE	1	
16	1S8-E8173-00	PIN, SHIFT	1	
17	1S8-E817A-00	ARM, SHIFT 3	1	
18	5YP-E8186-00	SCREW, ADJUSTING	1	
19	93210-068E9	O-RING	1	
20	95707-06500	NUT, FLANGE	1	
21	5HV-E6346-00	HOOK, SPRING	1	
22	55D-E8110-10	SHIFT PEDAL ASSY	1	
23	5H3-E8113-00	.COVER, SHIFT PEDAL	1	
24	97027-08020	BOLT, HEXAGON	1	



55D5440-R190

FIG. 19 FRAME

REF. NO.	PART NO.	DESCRIPTION	55D7				REMARKS
1	55D-F1110-20	FRAME COMP.	1				
2	91317-10100	BOLT,HEX.SOCKET HEAD	1				
3	90105-10861	BOLT, FLANGE	1				
4	90105-088D9	BOLT, FLANGE	1				
5	90105-088D8	BOLT, FLANGE	2				
6	90201-08804	WASHER, PLATE	3				
7	90201-101J1	WASHER, PLATE	3				
8	90179-08818	NUT	3				
9	90179-10811	NUT	2				
10	1S8-F1315-00	STAY, ENGINE 1	1				
11	1S8-F1316-00	STAY, ENGINE 2	1				
12	1S8-F139R-00	COVER 2	2				
13	1S8-F139X-00	DAMPER	1				
14	90480-01868	GROMMET	2				
15	1S8-F117G-00	PROTECTOR	1				
16	55D-F8100-01	TOOL KIT	1				

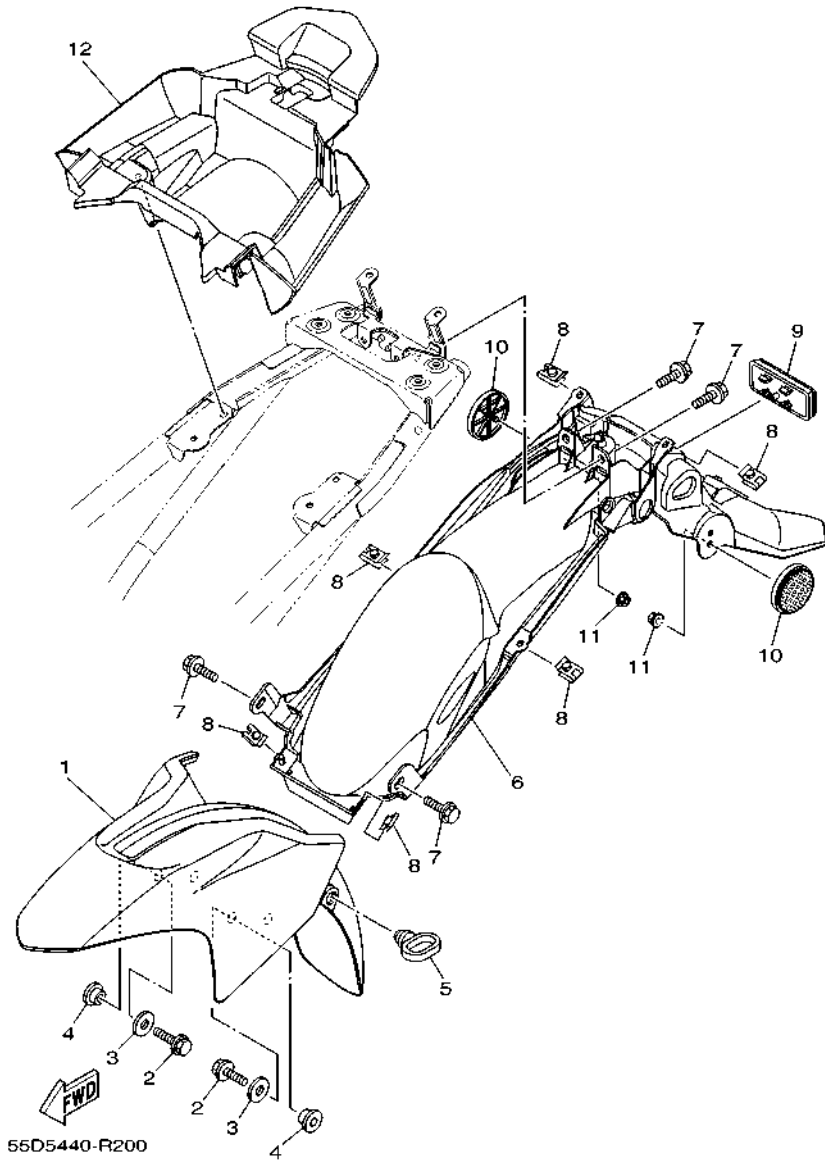
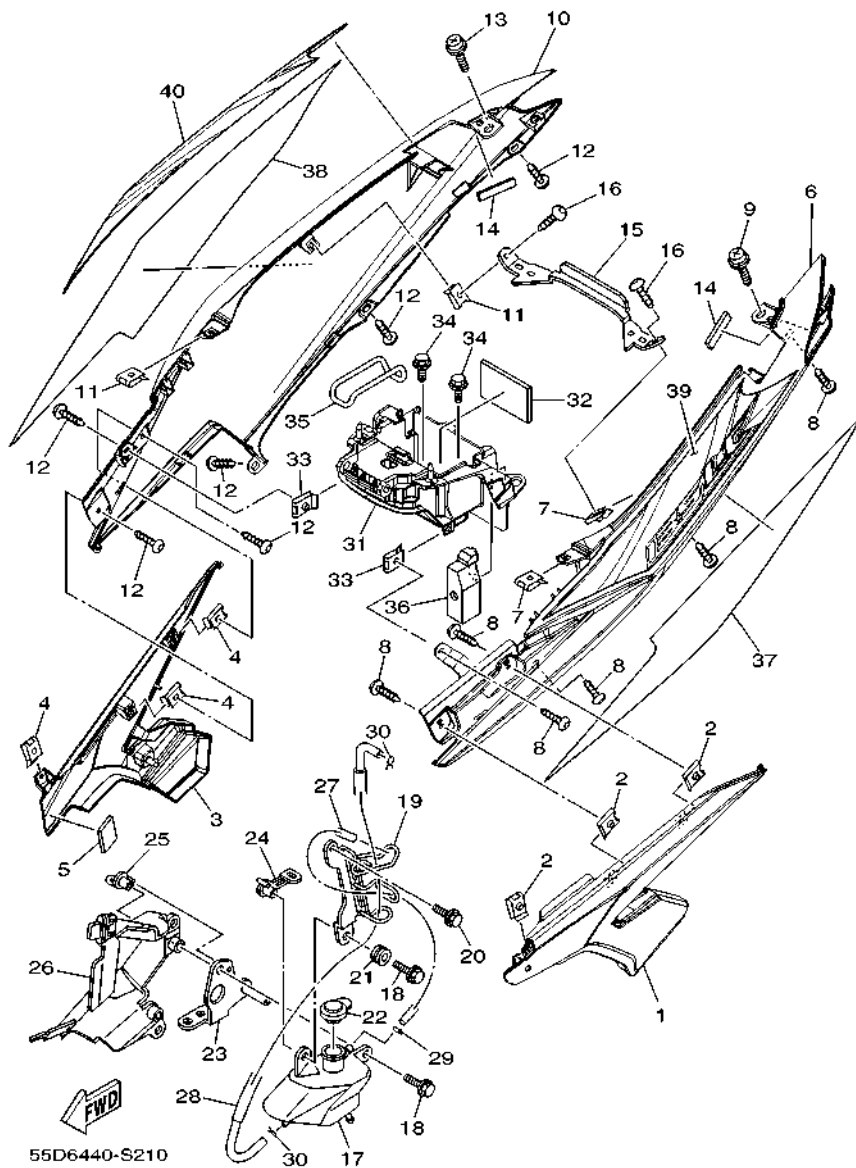


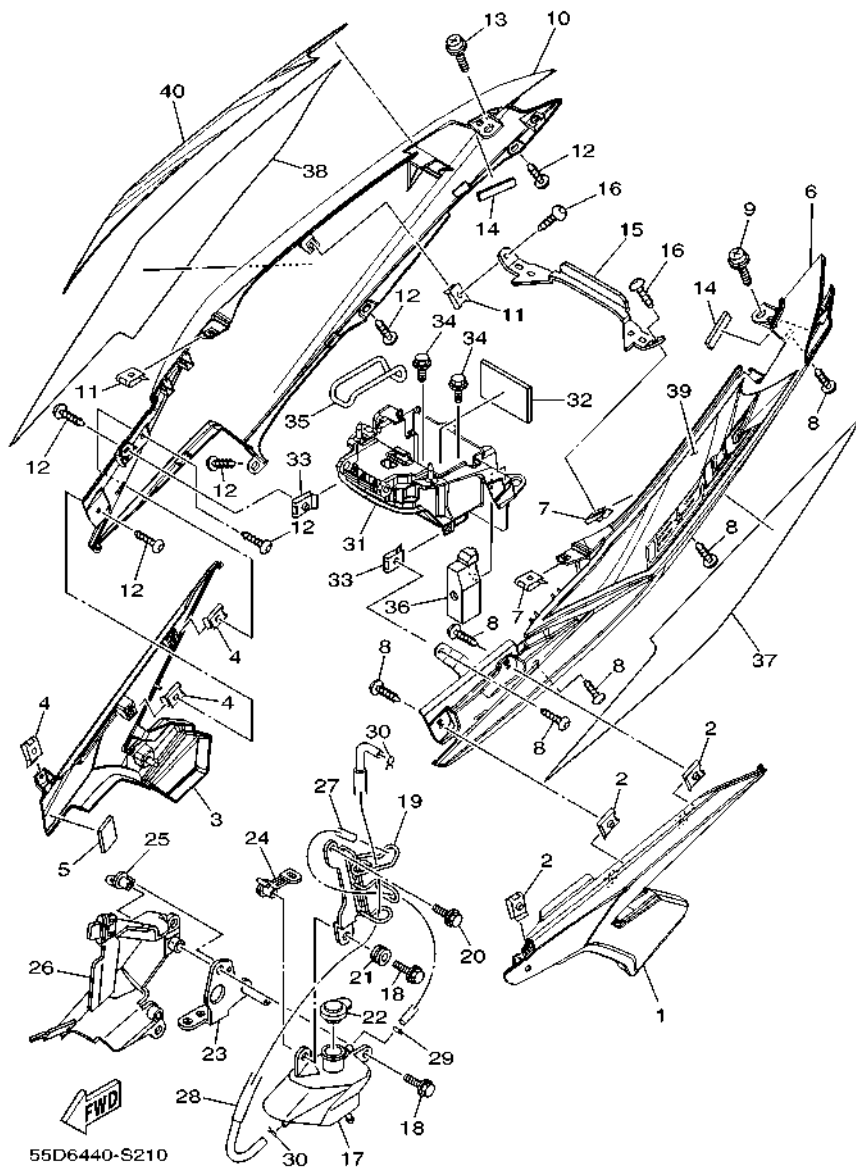
FIG. 20 FENDER

REF. NO.	PART NO.	DESCRIPTION	55D7	REMARKS
1	55C-F1511-00-P2	FENDER, FRONT	1	UR FOR RM7
	55C-F1511-00-P8	FENDER, FRONT	1	UR MBL2 FOR SMX
	55C-F1511-00-P7	FENDER, FRONT	1	UR VPBC5 FOR S3
	55C-F1511-00-P9	FENDER, FRONT	1	UR FOR MS1
2	95827-06016	BOLT, FLANGE	4	
3	90201-06072	WASHER, PLATE	4	
4	90387-06804	COLLAR	4	
5	15K-F1518-00	HOLDER, CABLE	1	
6	55C-F1611-10	FENDER, REAR	1	
7	90119-06044	BOLT, WITH WASHER	4	
8	90183-05807	NUT, SPRING	6	
9	55D-H5130-00	REAR REFLECTOR ASSY	1	
10	1CJ-H5111-00	REFLECTOR, FRONT 1	2	
11	95702-06500	NUT, FLANGE	2	
12	55C-F160E-00	BOX	1	



**FIG. 21 SIDE COVER**

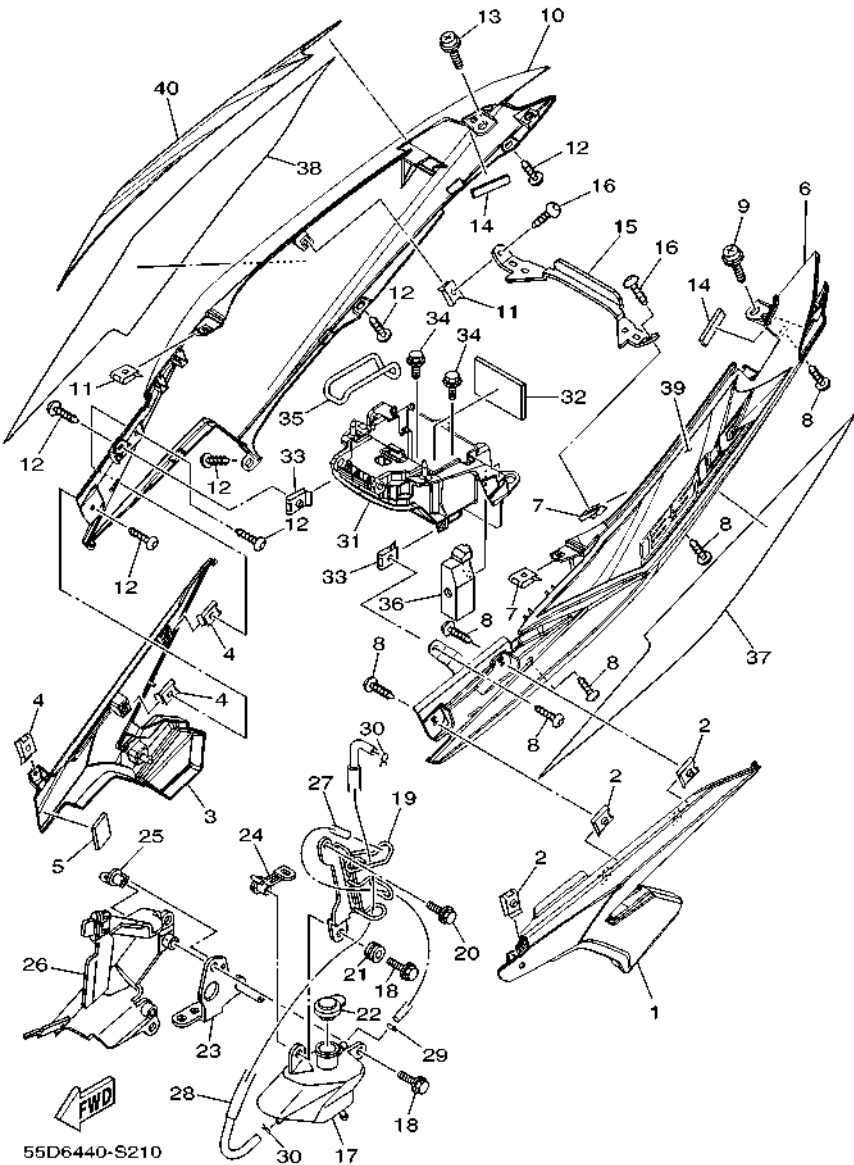
REF. NO.	PART NO.	DESCRIPTION	55D7		REMARKS
1	55C-F1711-00-P0	COVER, SIDE 1	1		UR FOR RM7
	55C-F1711-00-P3	COVER, SIDE 1	1		UR MBL2 FOR SMX
	55C-F1711-00-PA	COVER, SIDE 1	1		UR VPBC5 FOR S3
	55C-F1711-00-P2	COVER, SIDE 1	1		UR SMX FOR MS1
2	90183-05807	NUT, SPRING	3		
3	55C-F1721-00-P0	COVER, SIDE 2	1		UR FOR RM7
	55C-F1721-00-P3	COVER, SIDE 2	1		UR MBL2 FOR SMX
	55C-F1721-00-PA	COVER, SIDE 2	1		UR VPBC5 FOR S3
	55C-F1721-00-P2	COVER, SIDE 2	1		UR SMX FOR MS1
4	90183-05807	NUT, SPRING	3		
5	90520-02806	DAMPER, PLATE	1		
6	55C-F1731-00-P0	COVER, SIDE 3	1		SMX FOR RM7,SMX
	55C-F1731-00-P4	COVER, SIDE 3	1		FOR S3
	55C-F1731-00-P5	COVER, SIDE 3	1		FOR MS1
7	90183-05807	NUT, SPRING	2		
8	97707-50012	SCREW, TRUSS HEAD TAPPING	6		
9	90159-06181	SCREW, WITH WASHER	1		
10	55C-F1741-00-P0	COVER, SIDE 4	1		SMX FOR RM7,SMX
	55C-F1741-00-P4	COVER, SIDE 4	1		FOR S3
	55C-F1741-00-P5	COVER, SIDE 4	1		FOR MS1
11	90183-05807	NUT, SPRING	2		
12	97707-50012	SCREW, TRUSS HEAD TAPPING	6		
13	90159-06181	SCREW, WITH WASHER	1		
14	90520-04806	DAMPER, PLATE	2		
15	55C-F172E-00	STAY, SIDE COVER 1	1		
16	97707-50012	SCREW, TRUSS HEAD TAPPING	2		
17	1S9-F1871-01	TANK, RECOVERY	1		



**FIG. 21 SIDE COVER**

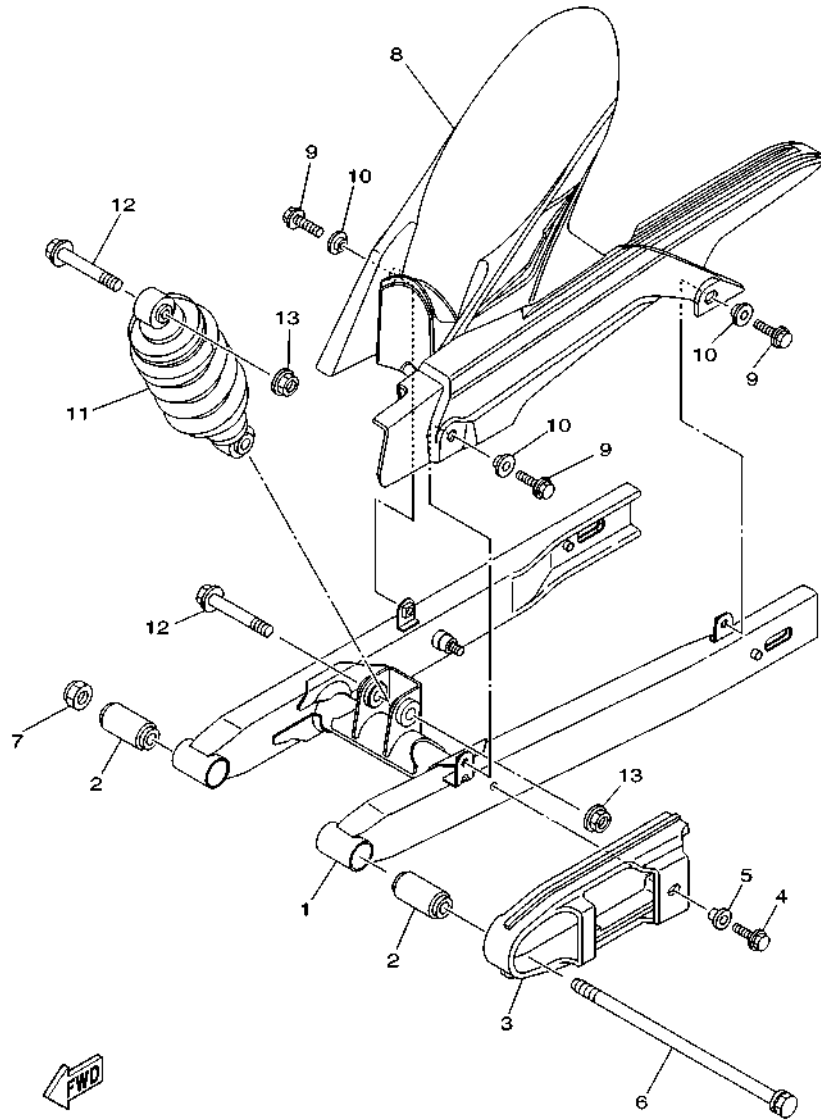
REF. NO.	PART NO.	DESCRIPTION	55D7	REMARKS
18	90119-06137	BOLT, WITH WASHER	2	
19	5YP-F172K-00	BRACKET 1	1	
20	95807-06020	BOLT, FLANGE	1	
21	90480-13805	GROMMET	1	
22	5YP-F1875-00	CAP	1	
23	1S8-F172L-00	BRACKET 2	1	
24	5YP-F172M-00	BRACKET 3	1	
25	55P-F1173-00	BOSS, WIRE HOLDER	1	
26	1S8-F172W-00	COVER	1	
27	90445-09823	HOSE	1	
28	55C-F1817-00	PIPE 2	1	
29	90467-08003	CLIP	1	
30	90467-09006	CLIP	2	
31	55C-F177G-00	BOX, BATTERY	1	
32	90520-02807	DAMPER, PLATE	1	
33	90183-05807	NUT, SPRING	2	
34	90119-06137	BOLT, WITH WASHER	2	
35	5VW-H2131-00	BAND, BATTERY	1	
36	1S8-E4293-00	COVER 1	1	
37	55D-F174G-D0	GRAPHIC 3	1	UR FOR RM7
	55D-F174G-E0	GRAPHIC 3	1	UR FOR SMX
	55D-F174G-F0	GRAPHIC 3	1	UR FOR S3
	55D-F174G-G0	GRAPHIC 3	1	UR FOR MS1
38	55D-F174H-D0	GRAPHIC 4	1	UR FOR RM7
	55D-F174H-E0	GRAPHIC 4	1	UR FOR SMX
	55D-F174H-F0	GRAPHIC 4	1	UR FOR S3
	55D-F174H-G0	GRAPHIC 4	1	UR FOR MS1

FIG. 21 SIDE COVER



REF. NO.	PART NO.	DESCRIPTION	55D7	REMARKS
39	55D-F174J-80	GRAPHIC 5	1	UR FOR RM7
	55D-F174J-90	GRAPHIC 5	1	UR FOR SMX
	55D-F174J-A0	GRAPHIC 5	1	UR FOR S3
	55D-F174J-B0	GRAPHIC 5	1	UR FOR MS1
40	55D-F174K-80	GRAPHIC 6	1	UR FOR RM7
	55D-F174K-90	GRAPHIC 6	1	UR FOR SMX
	55D-F174K-A0	GRAPHIC 6	1	UR FOR S3
	55D-F174K-B0	GRAPHIC 6	1	UR FOR MS1

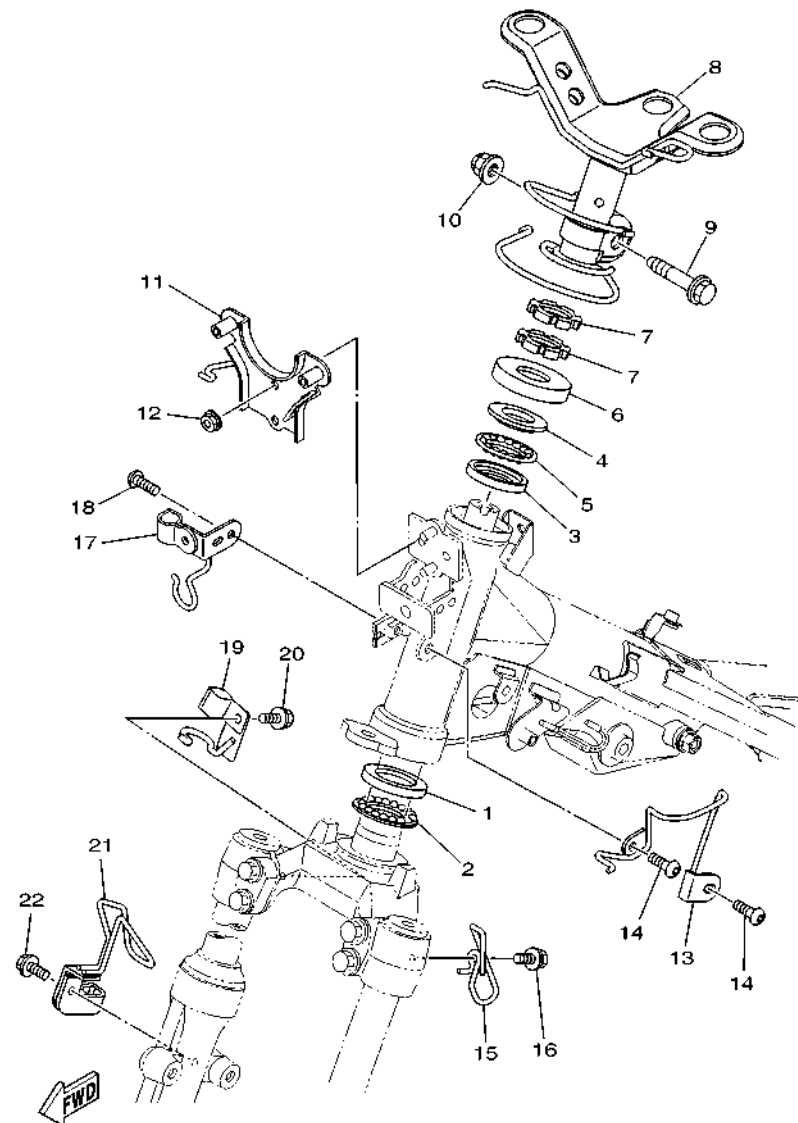




55S1460-K220

FIG. 22 REAR ARM & SUSPENSION

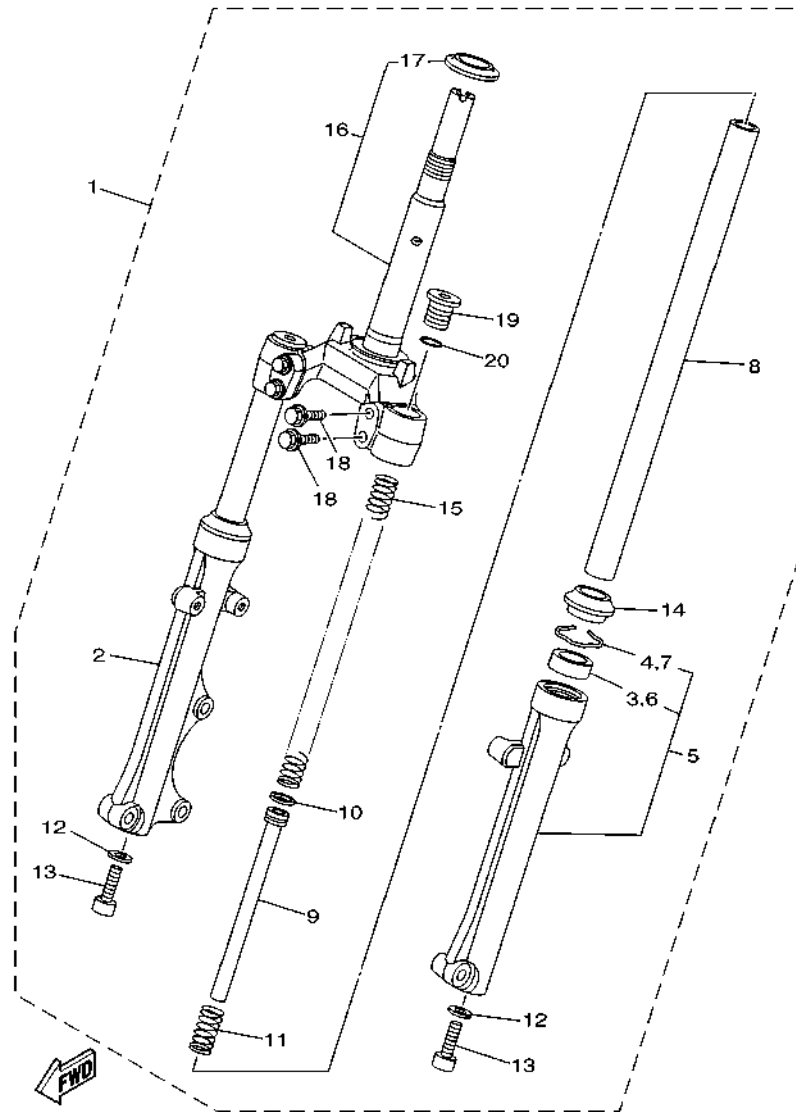
REF. NO.	PART NO.	DESCRIPTION	55D7				REMARKS
1	55D-F2110-00	REAR ARM COMP.	1				
2	4UL-F2123-00	BUSH 1	2				
3	1S8-F2151-00	SEAL, GUARD	1				
4	95807-06012	BOLT, FLANGE	1				
5	90387-06681	COLLAR	1				
6	50C-F2141-00	SHAFT, PIVOT	1				
7	95617-12100	NUT, U	1				
8	55D-F1650-00	REAR FENDER COMP.	1				
9	95827-06014	BOLT, FLANGE	3				
10	90387-07819	COLLAR	3				
11	55C-F2210-00	SHOCK ABSORBER ASSY, REAR	1				
12	90105-10323	BOLT, FLANGE	2				
13	95602-10200	NUT, S/L FLANGE	2				



55C5440-N230

**FIG. 23 STEERING**

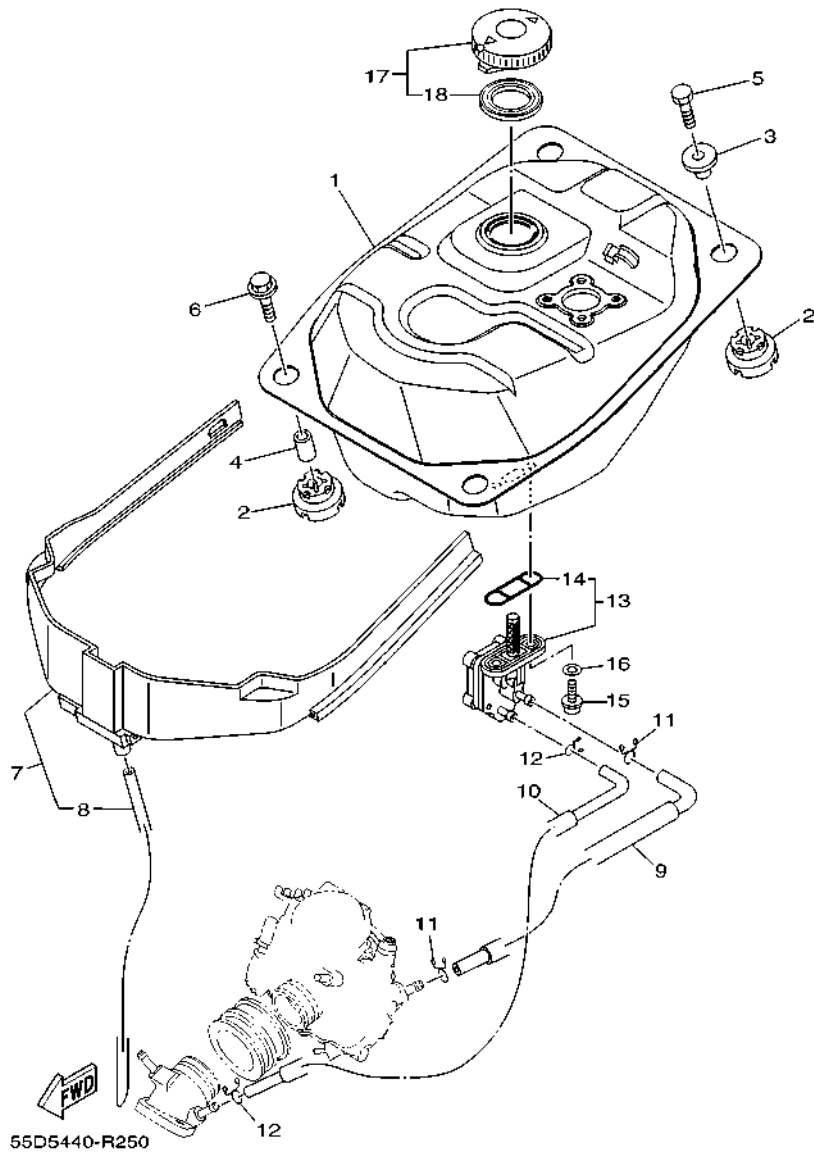
REF. NO.	PART NO.	DESCRIPTION	55D7				REMARKS
1	1KL-F3412-10	RACE, BALL 2	1				
2	5VL-F341E-10	RETAINER, BALL BEARING	1				
3	4RT-F3412-10	RACE, BALL 2	1				
4	4RT-F3411-10	RACE, BALL 1	1				
5	1P6-F341E-10	RETAINER, BALL BEARING	1				
6	5TL-F3416-00	COVER, BALL RACE 2	1				
7	90179-25802	NUT	2				
8	55C-F3461-00	BRACKET, HANDLE	1				
9	90105-10036	BOLT, FLANGE	1				
10	90185-10154	NUT, SELF-LOCKING	1				
11	55C-F331A-10	STAY	1				
12	95707-06500	NUT, FLANGE	2				
13	55C-F1161-10	HOLDER, CABLE	1				
14	92017-06010	BOLT, BUTTON HEAD	2				
15	55C-F3389-00	GUIDE, CABLE	1				
16	90119-06044	BOLT, WITH WASHER	1				
17	55C-F5875-10	HOLDER, BRAKE HOSE 1	1				
18	92017-06010	BOLT, BUTTON HEAD	2				
19	55P-F587A-00	HOLDER, BRAKE HOSE	1				
20	95807-06012	BOLT, FLANGE	1				
21	55C-F5876-10	HOLDER, BRAKE HOSE 2	1				
22	95807-06012	BOLT, FLANGE	1				



50C1460-K240

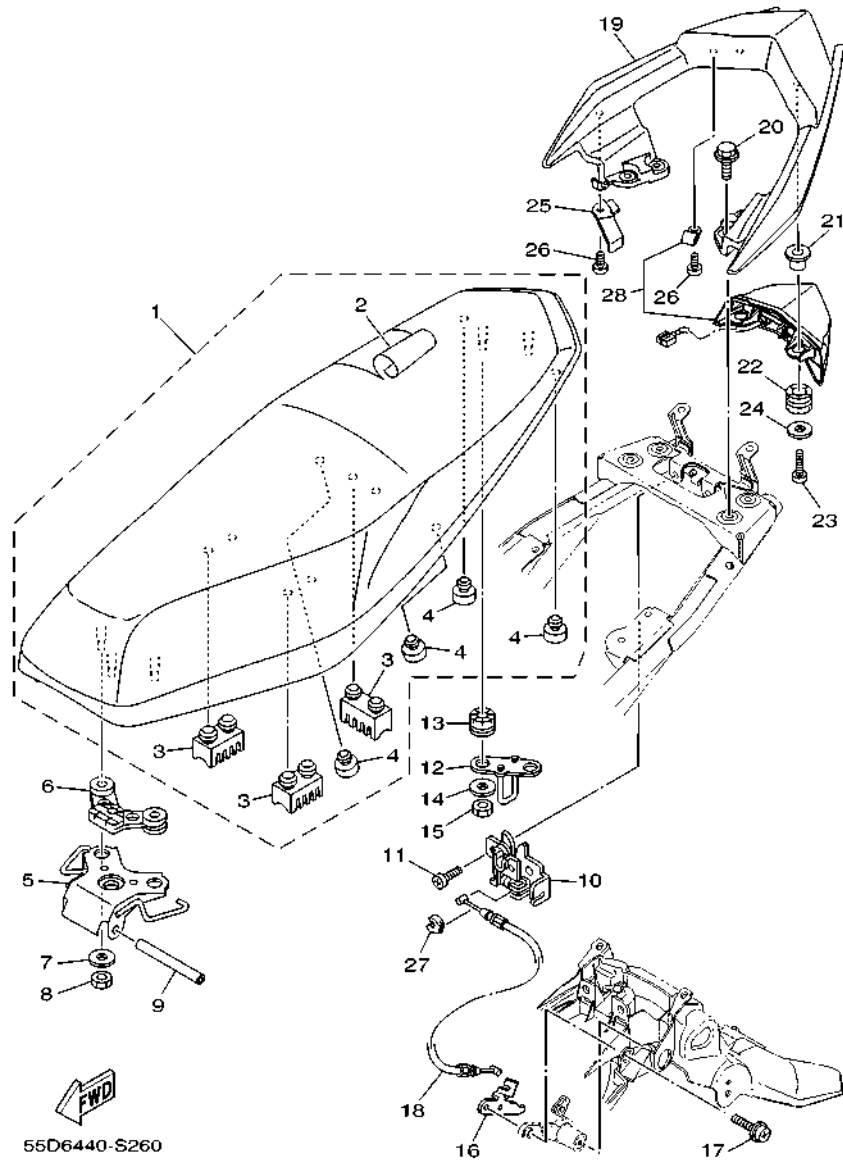
FIG. 24 FRONT FORK

REF. NO.	PART NO.	DESCRIPTION	55D7				REMARKS
1	55D-F3100-10	FRONT FORK ASSY	1				
2	55P-F3136-10	.TUBE, OUTER 2	1				
3	4UV-F3145-00	.OIL SEAL	1				
4	5P0-F3156-00	.RING, SNAP	1				
5	55P-F3126-10	.TUBE, OUTER (L.H)	1				
6	4UV-F3145-00	.OIL SEAL	1				
7	5P0-F3156-00	.RING, SNAP	1				
8	55C-F3110-00	.INNER TUBE COMP.1	2				
9	5P2-F3170-00	.CYLINDER COMP., FRONT FORK	2				
10	2JG-F3157-00	.RING, PISTON	2				
11	5TF-F3152-00	.SPRING, SUB	2				
12	509-F3158-L0	.GASKET	2				
13	31D-F3181-50	.BOLT, HEXAGON SOCKET HEAD	2				
14	5LL-F3144-00	.SEAL, DUST	2				
15	50C-F3141-00	.SPRING, FRONT FORK	2				
16	50C-F3340-10	.UNDER BRACKET COMP.	1				
17	156-F3411-00	.RACE, BALL 1	1				
18	5YW-F3346-10	.BOLT 1	4				
19	4VK-F3111-10	.BOLT, CAP	2				
20	2JG-F3147-00	.O-RING	2				



**FIG. 25 FUEL TANK**

REF. NO.	PART NO.	DESCRIPTION	55D7				REMARKS
1	1S8-F4110-00	FUEL TANK COMP.	1				
2	1S8-F4339-00	GROMMET	4				
3	1S8-F4638-00	COLLAR	2				
4	1S8-F4397-00	COLLAR	2				
5	97007-06025	BOLT	2				
6	90119-06190	BOLT, WITH WASHER	2				
7	21S-F4141-00	PROTECTOR, FUEL TANK	1				
8	90445-07812	.HOSE	1				
9	55C-F4311-00	PIPE, FUEL 1	1				
10	55C-F4312-00	PIPE 2	1				
11	90467-09006	CLIP	2				
12	90467-08075	CLIP	2				
13	5YP-F4500-01	FUEL COCK ASSY 1	1				
14	4X8-24512-00	.O-RING	1				
15	90149-06011	SCREW	2				
16	90202-05193	WASHER, PLATE	2				
17	5LW-F4610-01	CAP ASSY	1				
18	3T5-24612-20	.PACKING, CAP	1				

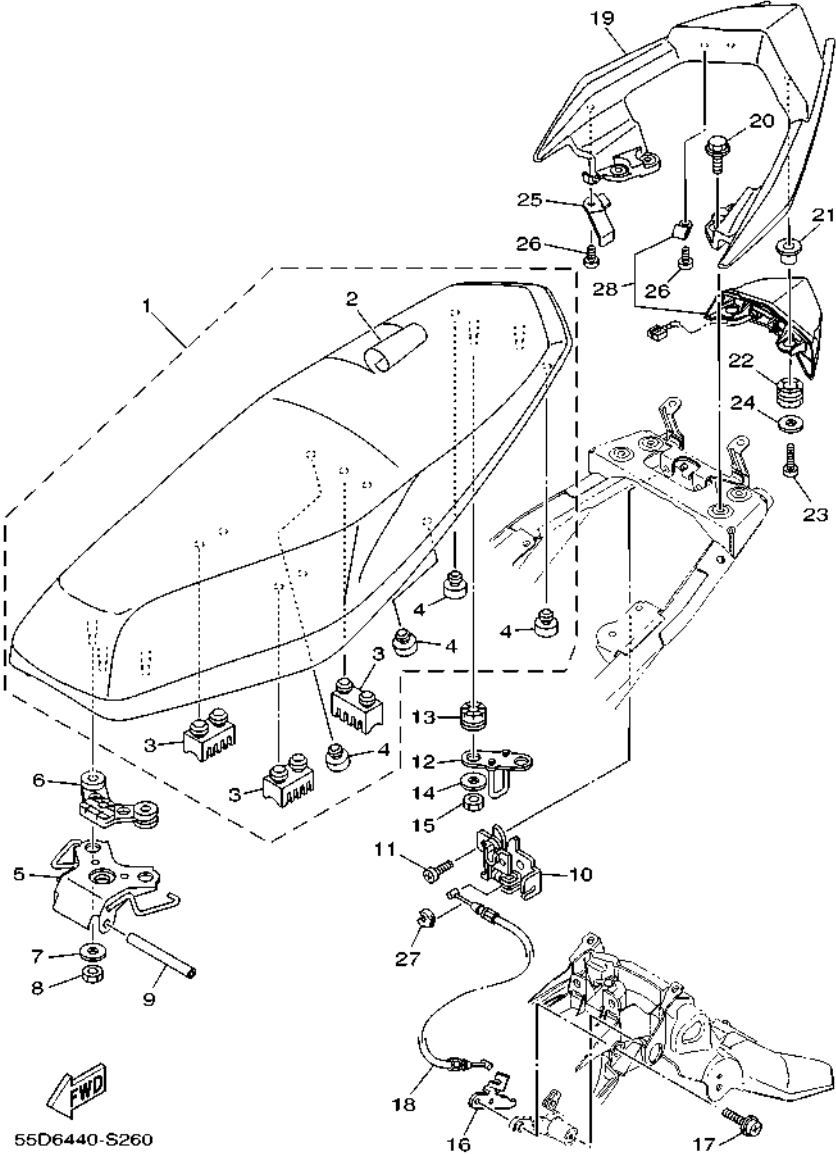


55D6440-S260

FIG. 26 SEAT

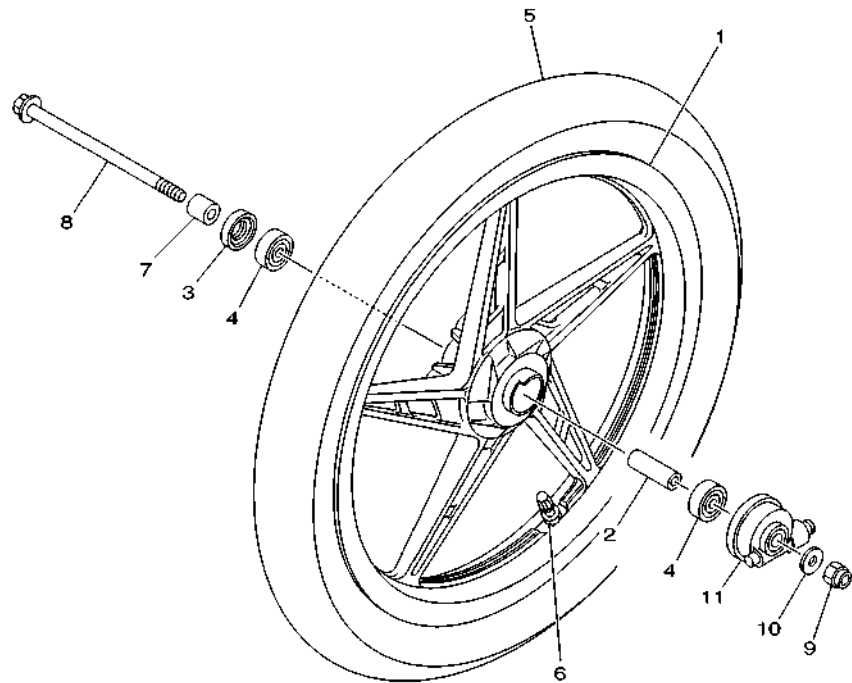
REF. NO.	PART NO.	DESCRIPTION	55D7				REMARKS
1	55C-F4730-10	DOUBLE SEAT ASSY	1				
2	55C-F470F-10	.SEAT COVER COMP.	1				
3	5TF-F4723-00	.DAMPER, SEAT	3				
4	4HF-F4741-00	.PAD, SEAT	4				
5	55C-F4726-00	HINGE, SEAT	1				
6	1S8-F4742-00	GROMMET	1				
7	90201-068N7	WASHER, PLATE	3				
8	95307-06600	NUT	3				
9	2WB-F4727-00	PIN, SEAT FITTING	1				
10	1DY-F4780-00	SEAT LOCK ASSY	1				
11	98507-06012	SCREW, PAN HEAD	2				
12	1S8-F4728-00	BRACKET, SEAT	1				
13	90480-14872	GROMMET	2				
14	90201-06071	WASHER, PLATE	2				
15	95307-06600	NUT	2				
16	55C-F117K-00	STAY, LOCK	1				
17	90159-06033	SCREW, WITH WASHER	1				
18	55C-F478E-10	CABLE, SEAT LOCK	1				
19	55D-F4773-00-P3	HANDLE, SEAT	1				SMX
20	95827-06020	BOLT, FLANGE	4				
21	90387-061N0	COLLAR	2				
22	55D-F4742-00	GROMMET	2				
23	98507-06020	SCREW, PAN HEAD	2				
24	90201-06882	WASHER, PLATE	2				
25	55D-F464U-00	PLATE, STOPPER	1				
26	98507-05010	SCREW, PAN HEAD	2				
27	1S8-F4768-00	STOPPER	1				

**FIG. 26 SEAT**



REF. NO.	PART NO.	DESCRIPTION	55D7						REMARKS
28	55D-H4790-00	HIGH MOUNT STOP LAMP ASSY	1						

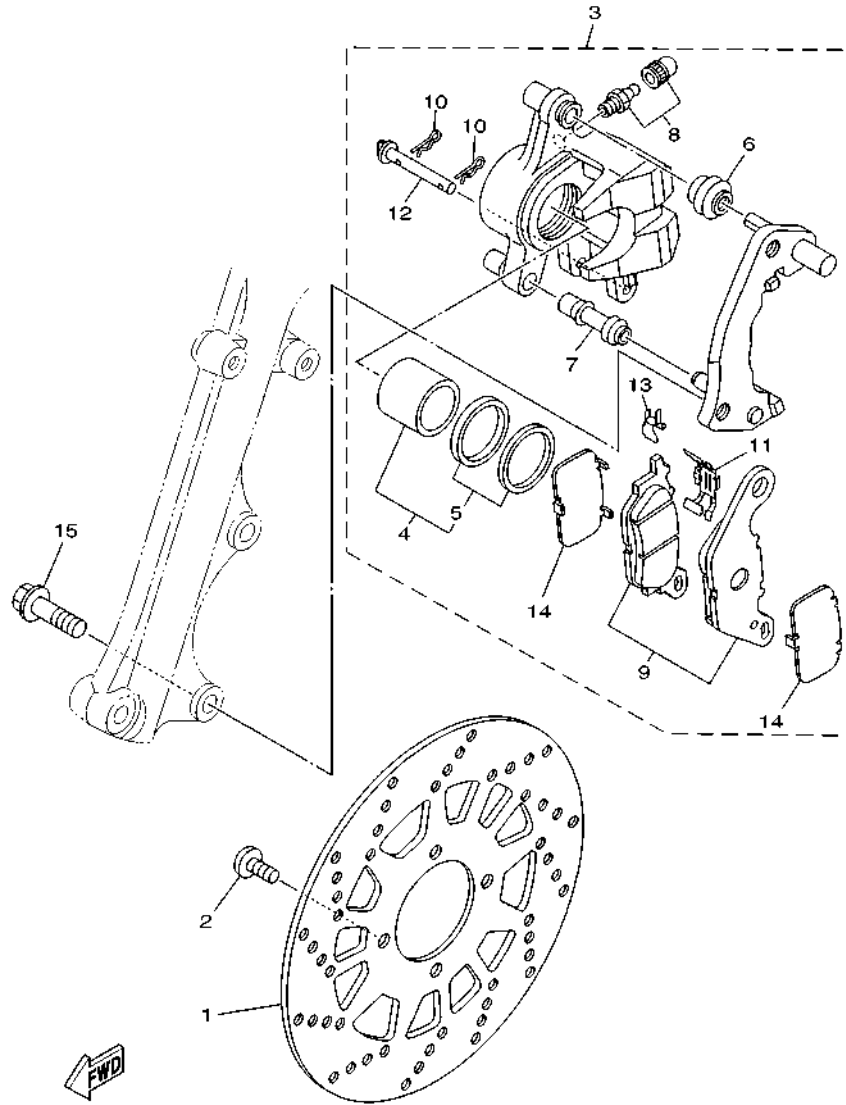
**FIG. 27 FRONT WHEEL**



REF. NO.	PART NO.	DESCRIPTION	55D7		REMARKS
1	1S8-F5168-00-0X	CAST WHEEL, FRONT	1		YB/W FOR RM7,SMX,S3
	1S8-F5168-00-P2	CAST WHEEL, FRONT	1		LLGS6 FOR MS1
2	90560-10292	SPACER	1		
3	93106-20816	OIL SEAL	1		
4	93306-300X8	BEARING	2		
5	94107-17873	TIRE(70/90-17M/C 38P V421F TL)	1		VEE RUBBER
6	93900-00817	VALVE, RIM (TR412)	1		
7	90387-10277	COLLAR	1		
8	3NA-F5181-01	AXLE, WHEEL	1		
9	90185-10091	NUT, SELF-LOCKING	1		
10	90201-101J1	WASHER, PLATE	1		
11	5TN-F5190-01	GEAR UNIT ASSY	1		

  
1S81440-E270

**FIG. 28 FRONT BRAKE CALIPER**



55D1440-K280

REF. NO.	PART NO.	DESCRIPTION	55D7				REMARKS
1	31D-F582U-00	DISK, BRAKE (RIGHT)	1				
2	90111-08853	BOLT,HEX. SOCKET BUTTON	4				
3	44S-F580U-02	CALIPER ASSY (RIGHT)	1				
4	5P0-F5802-00	.PISTON ASSY, CALIPER	1				
5	5YP-F5803-50	..CALIPER SEAL KIT	1				
6	5YP-F5917-00	..BOOT, CALIPER	1				
7	5YP-F5937-00	..BOOT 2	1				
8	4C9-W0048-00	..BLEED SCREW KIT	1				
9	3C1-F5805-10	..BRAKE PAD KIT	1				
10	5YP-F5925-01	..CLIP	2				
11	5P0-F5919-01	..SUPPORT, PAD	1				
12	5YP-F5924-00	..PIN, PAD	1				
13	5YP-F5939-00	..CLIP, PAD	1				
14	5P0-F5827-00	..SHIM, CALIPER	2				
15	90105-10831	BOLT, FLANGE	2				



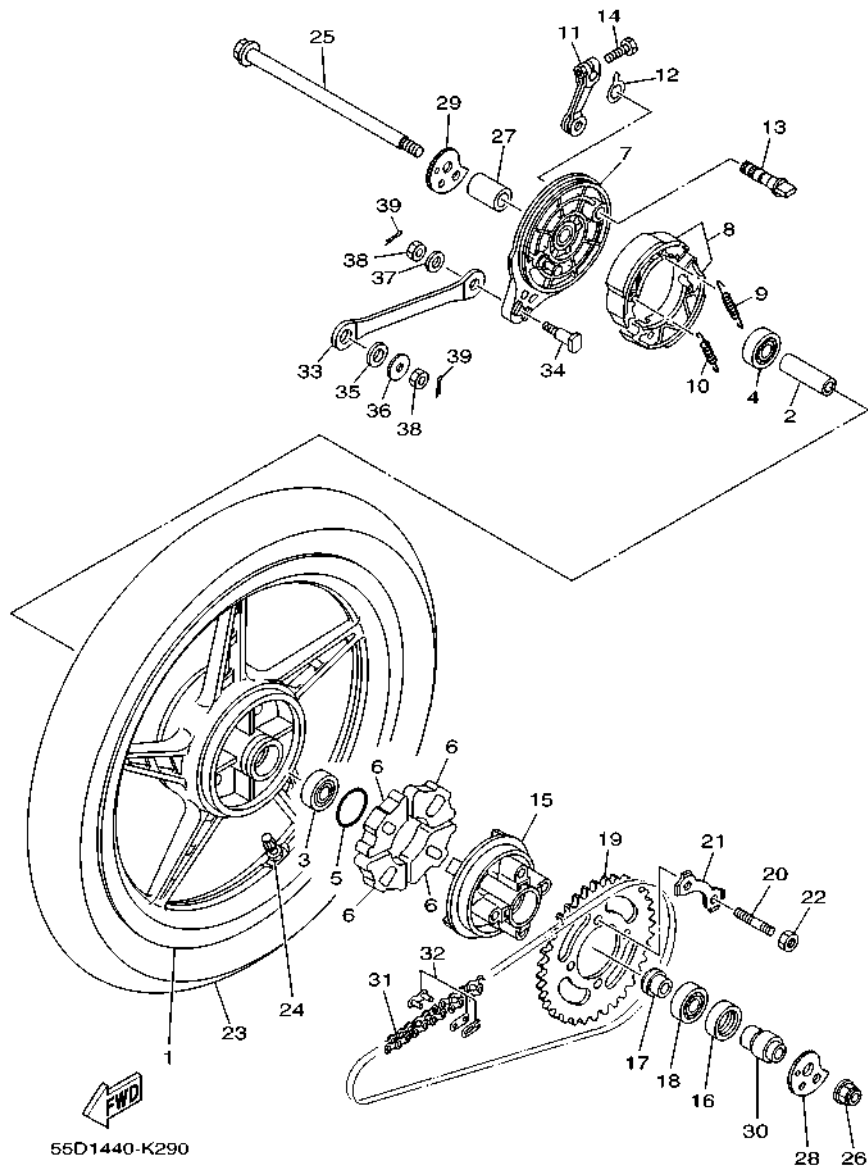


FIG. 29 REAR WHEEL

REF. NO.	PART NO.	DESCRIPTION	55D7			REMARKS
1	1S8-F5338-00-0X	CAST WHEEL, REAR	1			YB/W FOR RM7,SMX,S3
	1S8-F5338-00-P2	CAST WHEEL, REAR	1			LLGS6 FOR MS1
2	90560-12145	SPACER	1			
3	93306-301YN	BEARING	1			
4	93306-301YM	BEARING	1			
5	93210-41041	O-RING	1			
6	1S8-F5364-00	DAMPER	4			
7	1S8-F5321-00-33	PLATE, BRAKE SHOE	1			YB
8	5YP-F530K-00	BRAKE SHOE SET	1			
9	90506-12001	SPRING, TENSION	1			
10	90506-15001	SPRING, TENSION	1			
11	1S8-F5355-00	LEVER, CAMSHAFT	1			
12	5LW-F533A-00	PLATE, INDICATOR	1			
13	4UV-F5351-00	CAMSHAFT	1			
14	90101-06278	BOLT	1			
15	1S8-F5366-00	CLUTCH, HUB	1			
16	93106-26815	OIL SEAL	1			
17	90387-127Y0	COLLAR	1			
18	93306-004XB	BEARING	1			
19	3YR-F5439-10	SPROCKET, DRIVEN (39T)	1			
20	90116-08017	BOLT, STUD	4			
21	5XK-F5412-00	WASHER	2			
22	90170-08258	NUT	4			
23	94108-17868	TIRE(80/90-17M/C 50P V421R TL)	1			VEE RUBBER
24	93900-00817	VALVE, RIM (TR412)	1			
25	55S-F5381-00	AXLE, WHEEL	1			
26	95607-12200	NUT, SELF-LOCKING	1			

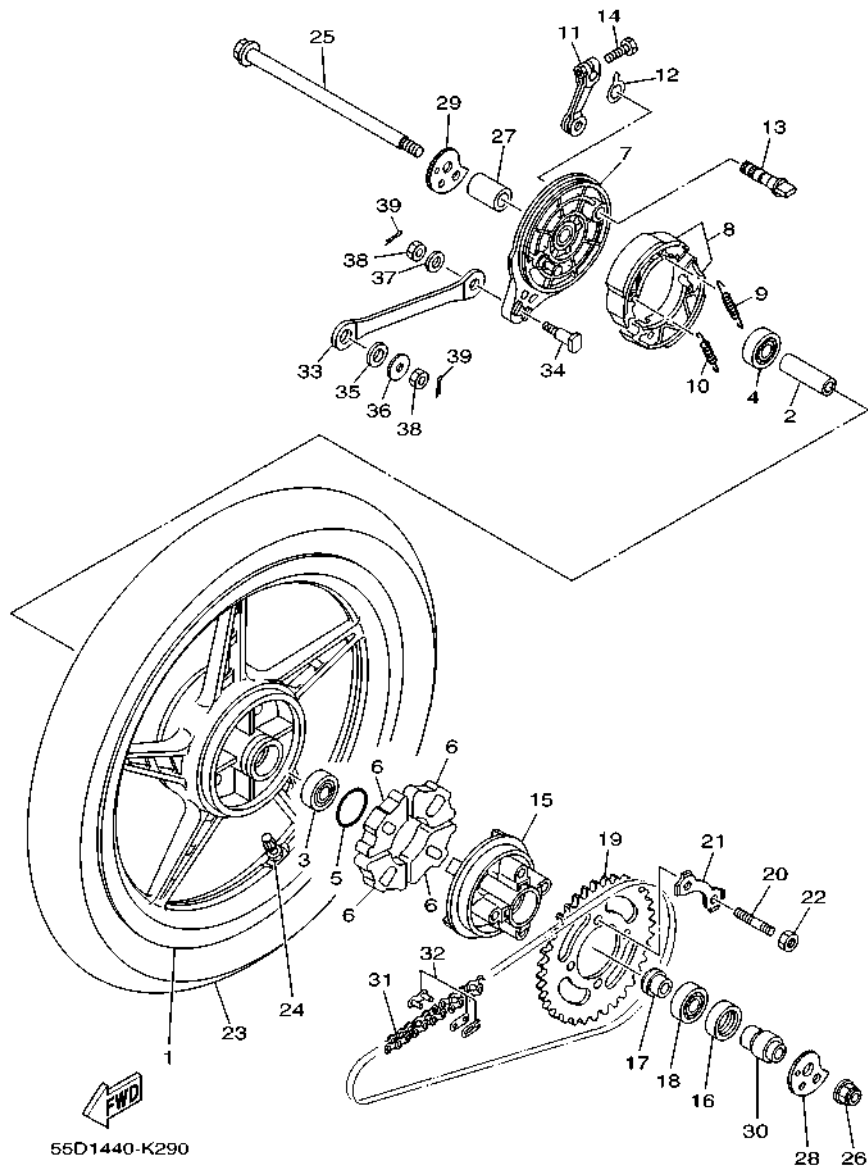
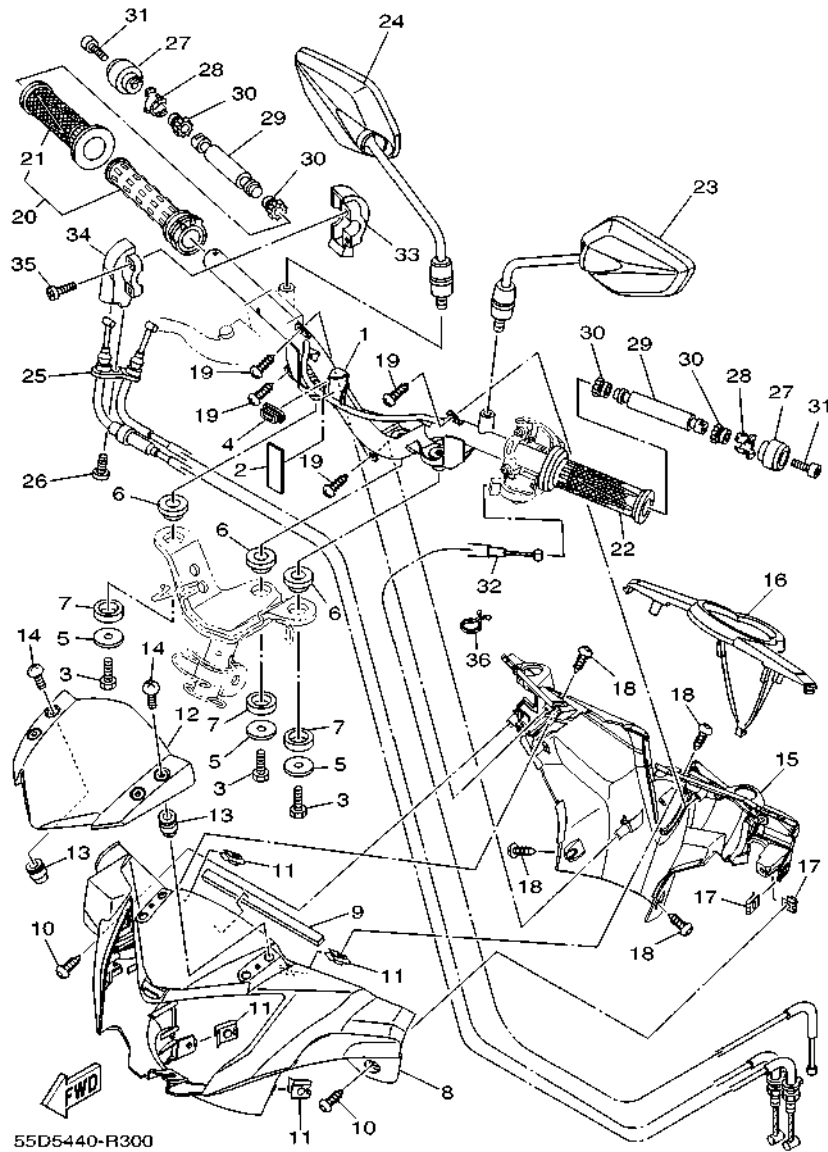


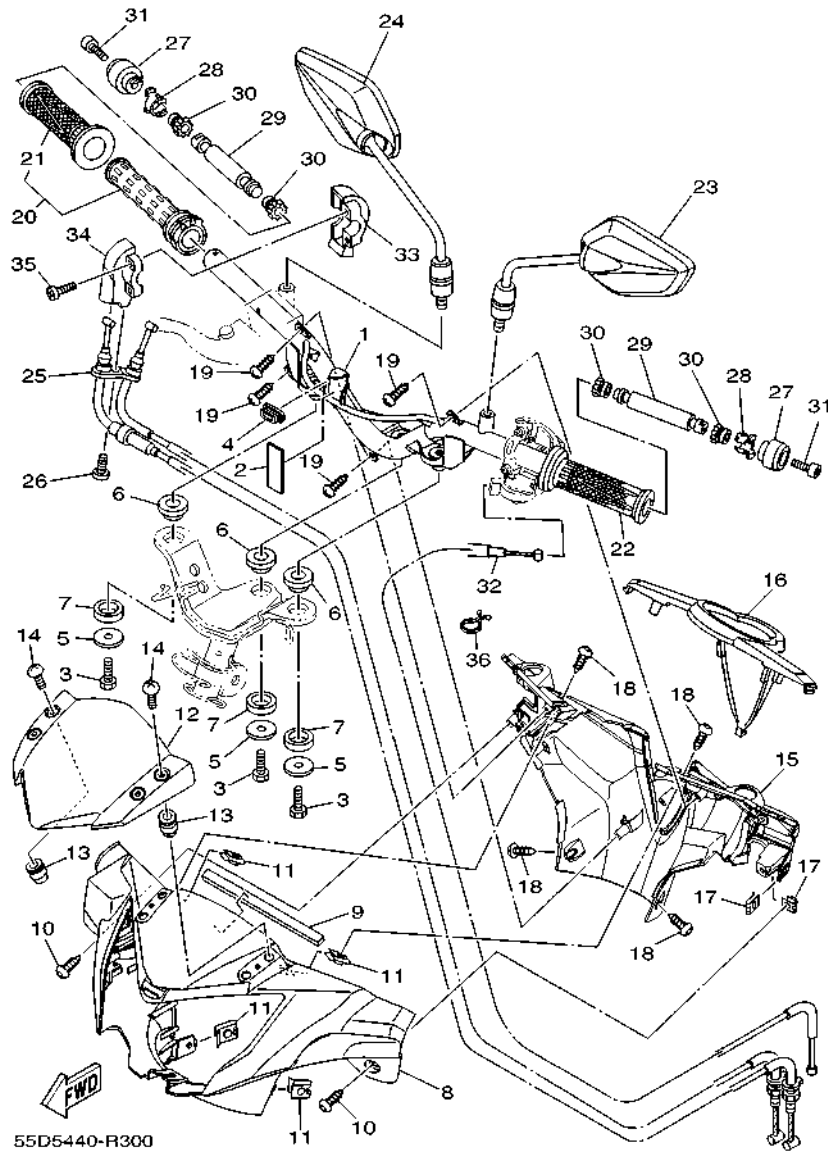
FIG. 29 REAR WHEEL

REF. NO.	PART NO.	DESCRIPTION	55D7				REMARKS
27	55D-F5383-00	COLLAR, WHEEL	1				
28	50C-F5388-00	PULLER, CHAIN 1	1				
29	50C-F5389-00	PULLER, CHAIN 2	1				
30	55D-F5377-00	COLLAR, WHEEL	1				
31	94568-84113	CHAIN (RK-M 428SB X 113L)	1				
32	94668-84001	JOINT, CHAIN (RK-M 428M)	1				
33	1S8-F5371-01	BAR, TENSION	1				
34	90109-08822	BOLT	1				
35	90202-15800	WASHER, PLATE	1				
36	90201-088N6	WASHER, PLATE	1				
37	92907-08200	WASHER	1				
38	95304-08700	NUT	2				
39	91401-20012	PIN, COTTER	2				



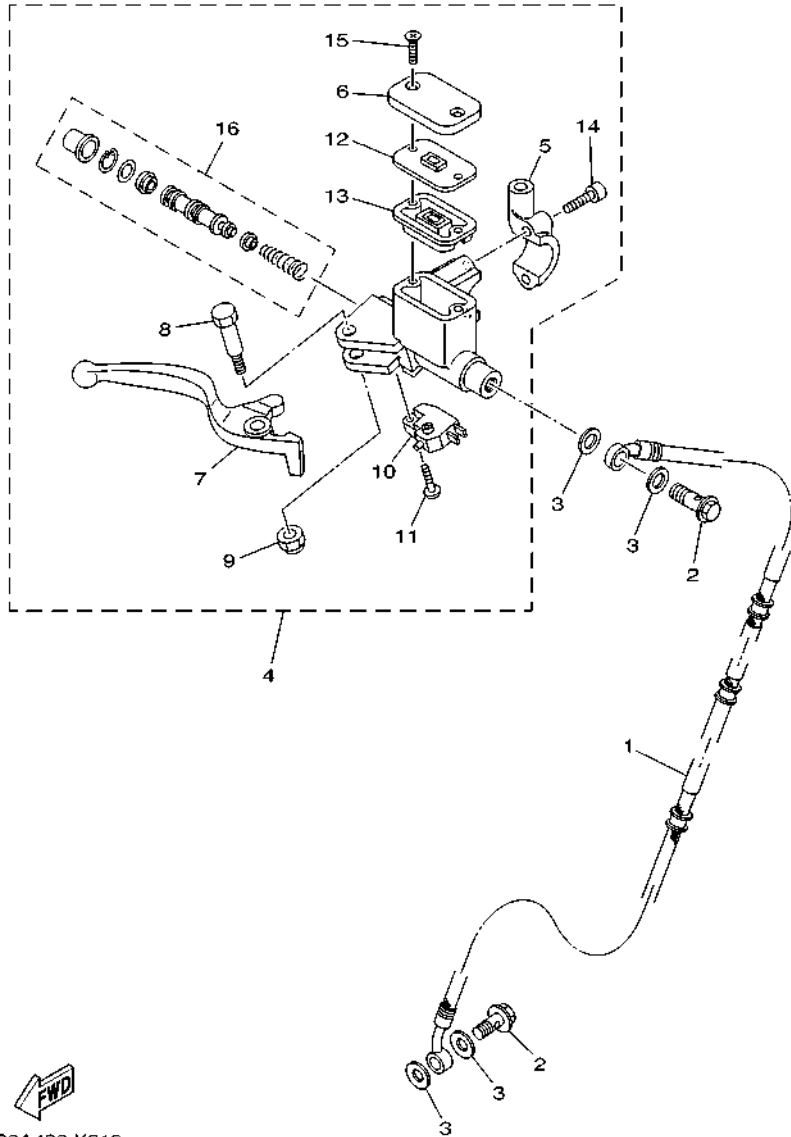
**FIG. 30 STEERING HANDLE & CABLE**

REF. NO.	PART NO.	DESCRIPTION	55D7	REMARKS
1	55D-F6210-00	HANDLE	1	
2	90520-02813	DAMPER, PLATE	1	
3	97007-08016	BOLT	3	
4	55C-F6326-00	GROMMET	1	
5	90201-08612	WASHER, PLATE	3	
6	1S8-F8217-00	DAMPER 1	3	
7	1S8-F8227-00	DAMPER 2	3	
8	55D-F6143-10-P0	COVER, HANDLE UPPER 1	1	UR FOR RM7
	55D-F6143-10-P1	COVER, HANDLE UPPER 1	1	UR FOR SMX,MS1
	55D-F6143-10-P2	COVER, HANDLE UPPER 1	1	UR VPBC5 FOR S3
9	90520-04813	DAMPER, PLATE	1	
10	97707-50014	SCREW, TRUSS HEAD TAPPING	2	
11	90183-05807	NUT, SPRING	4	
12	55D-F8381-00	WINDSHIELD	1	
13	90179-05802	NUT	4	
14	90150-05806	SCREW, ROUND HEAD	4	
15	55C-F6145-00	COVER, HANDLE UPPER 2	1	
16	55C-H3559-00-P9	COVER, METER	1	MBL2
17	90183-05807	NUT, SPRING	2	
18	97707-50014	SCREW, TRUSS HEAD TAPPING	4	
19	97707-50012	SCREW, TRUSS HEAD TAPPING	4	
20	55C-F6240-00	GRIP ASSY	1	
21	1S8-F6242-00	.GRIP (RIGHT)	1	
22	1S8-F6241-00	GRIP	1	
23	2WB-F6280-00	REAR VIEW MIRROR ASSY (LEFT)	1	
24	2WB-F6290-00	REAR VIEW MIRROR ASSY (RIGHT)	1	
25	55C-F6301-10	THROTTLE CABLE ASSY	1	



**FIG. 30 STEERING HANDLE & CABLE**

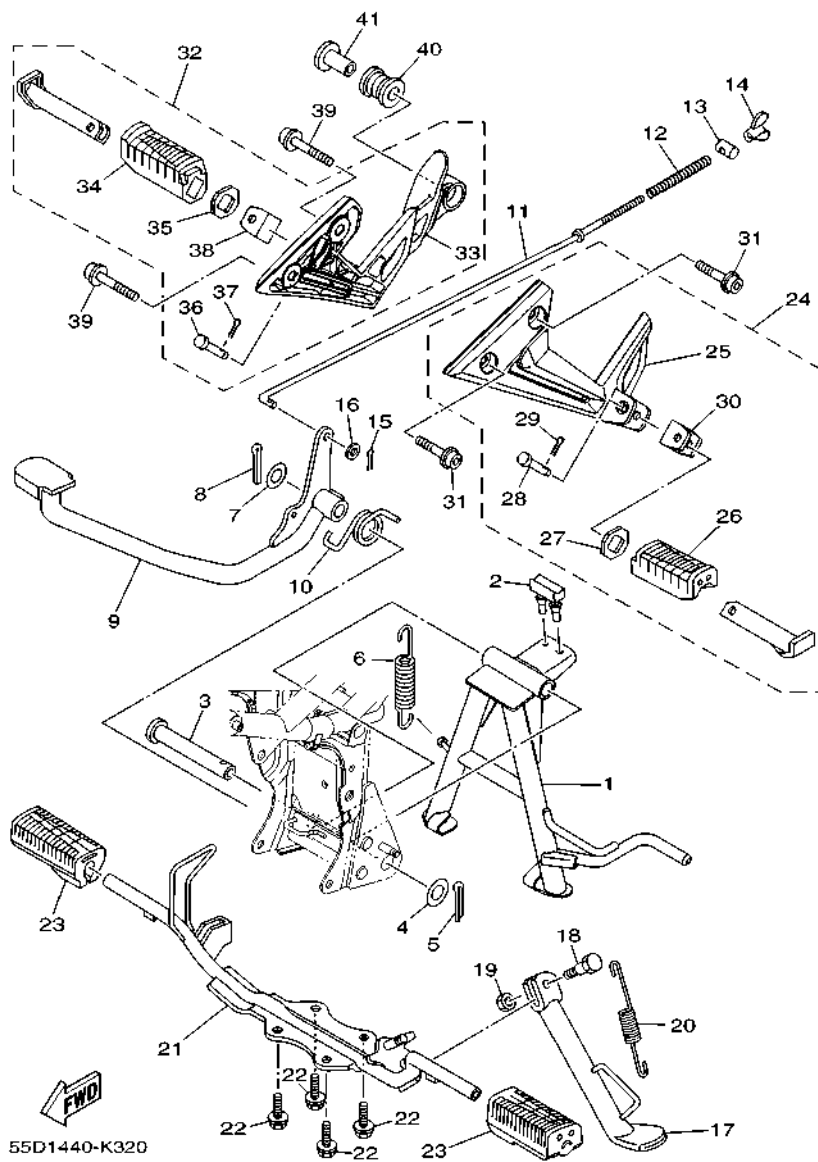
REF. NO.	PART NO.	DESCRIPTION	55D7				REMARKS
26	98507-05016	SCREW, PAN HEAD	1				
27	55C-F6246-00	END, GRIP	2				
28	16S-F6257-00	STOPPER	2				
29	55C-F622H-00	WEIGHT	2				
30	1S8-F622F-00	DAMPER, LOCATING 1	4				
31	91317-06030	BOLT, HEX. SOCKET HEAD	2				
32	55C-F6331-10	CABLE, STARTER 1	1				
33	5P2-F6281-00	CAP, GRIP UPPER	1				
34	5P2-F6282-00	CAP, GRIP UNDER	1				
35	98507-05025	SCREW, PAN HEAD	2				
36	90464-24803	CLAMP	1				



1S9A422-K310

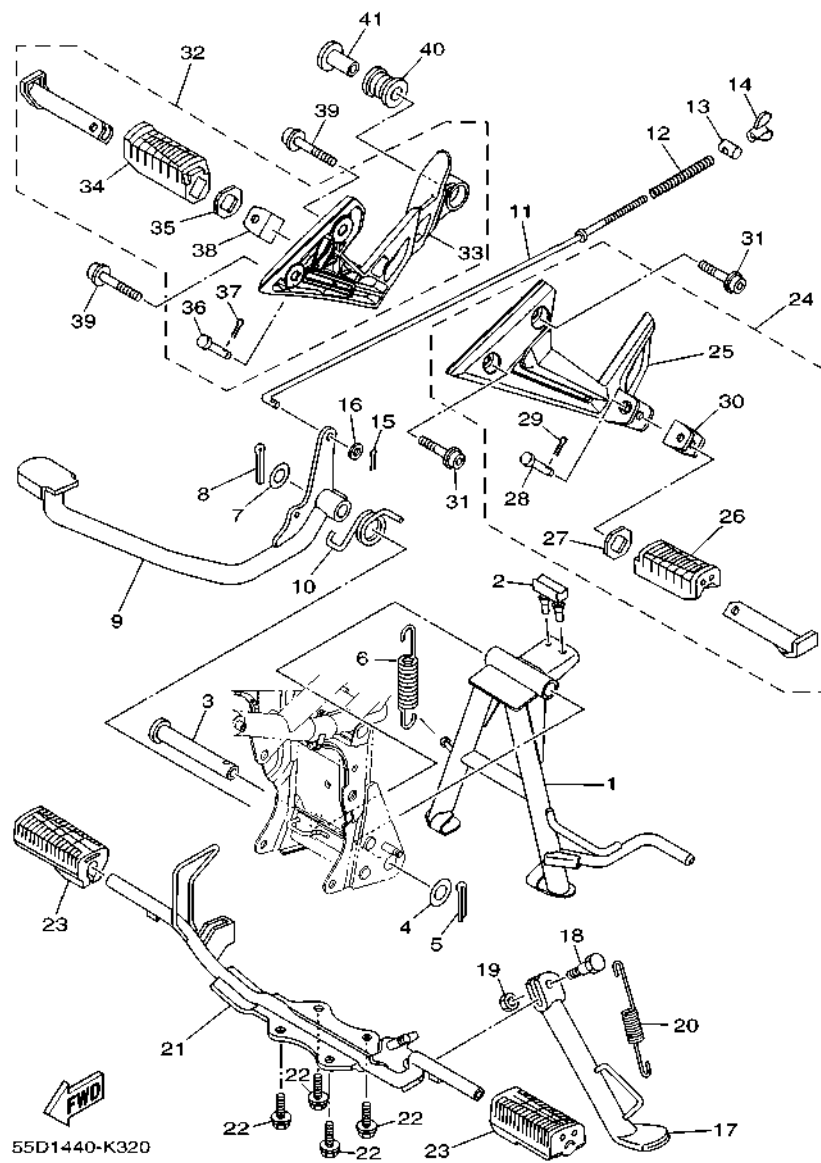
FIG. 31 FRONT MASTER CYLINDER

REF. NO.	PART NO.	DESCRIPTION	55D7			REMARKS
1	50C-F5872-00	HOSE, BRAKE 1	1			
2	90401-10812	BOLT, UNION	2			
3	90201-10118	WASHER, PLATE	4			
4	1S9-F583T-03	MASTER CYLINDER ASSY	1			
5	1S9-F5867-01	.BRACKET, MASTER CYLINDER	1			
6	5HV-F5852-00	.CAP, RESERVOIR	1			
7	1S9-H3922-01	.LEVER 2	1			
8	90109-06577	.BOLT	1			
9	9560M-06100	.NUT, U	1			
10	18D-H3980-00	.FRONT STOP SWITCH ASSY	1			
11	9760L-04212	.SCREW, PAN HEAD	1			
12	1S9-F585B-00	.PLATE, DIAPHRAGM	1			
13	5HV-F5854-10	.DIAPHRAGM, RESERVOIR	1			
14	1S9-F6332-00	.BOLT	2			
15	9870M-04012	.SCREW, FLAT HEAD	2			
16	1S9-W0041-00	.CYLINDER KIT, MASTER	1			



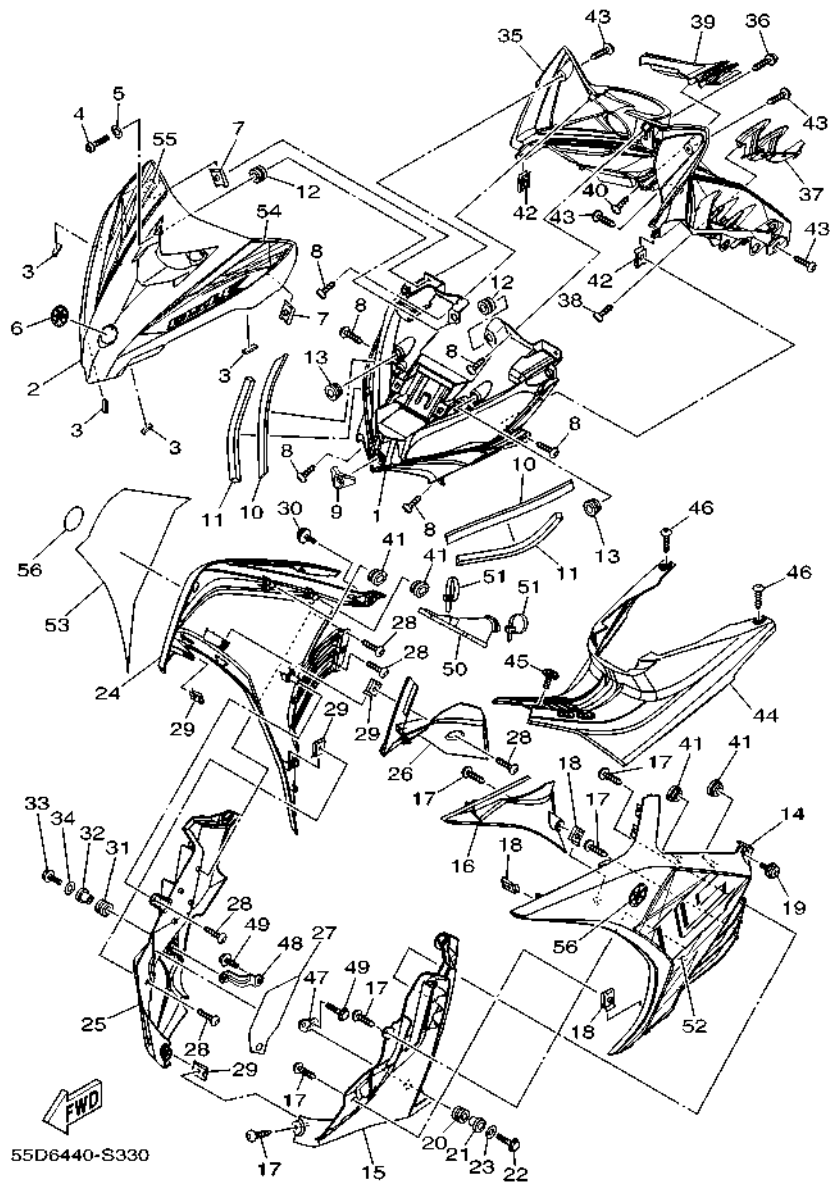
**FIG. 32 STAND & FOOTREST**

REF. NO.	PART NO.	DESCRIPTION	55D7				REMARKS
1	55D-F7111-00	STAND, MAIN	1				
2	1S8-F7114-00	STOPPER, MAIN STAND	1				
3	5YP-F7112-00	SHAFT, MAIN STAND	1				
4	90201-163H8	WASHER, PLATE	1				
5	91401-30030	PIN, COTTER	1				
6	90506-35806	SPRING, TENSION	1				
7	90201-158D1	WASHER, PLATE	1				
8	91401-30030	PIN, COTTER	1				
9	55D-F7211-00	PEDAL, BRAKE	1				
10	90508-40801	SPRING, TORSION	1				
11	55S-F7231-00	ROD, BRAKE	1				
12	90501-10245	SPRING, COMPRESSION	1				
13	90249-12008	PIN	1				
14	90175-06013	NUT, WING	1				
15	91401-20012	PIN, COTTER	1				
16	92907-06600	WASHER, PLATE	1				
17	1S8-F7311-00	STAND, SIDE	1				
18	90109-08034	BOLT	1				
19	95307-08700	NUT	1				
20	90506-23804	SPRING, TENSION	1				
21	1S8-F7411-00	FOOTREST 1	1				
22	95827-08016	BOLT, FLANGE	4				
23	5LL-F7413-00	COVER, FOOTREST	2				
24	55C-F7430-00-P1	REAR FOOTREST ASSY 1	1				SMX
25	55C-F7452-00-P1	.BRACKET, FOOTREST 1	1				SMX
26	5BU-F7433-00	.COVER, REAR FOOTREST	1				
27	5BU-F7445-00	.PLATE 1	1				



**FIG. 32 STAND & FOOTREST**

REF. NO.	PART NO.	DESCRIPTION	55D7				REMARKS
28	91701-08042	.PIN	1				
29	90252-23800	.PIN, COTTER	1				
30	5TF-F7314-00	.STOPPER	1				
31	90110-08199	BOLT, HEXAGON SOCKET HEAD	2				
32	55C-F7440-00-P1	REAR FOOTREST ASSY 2	1				SMX
33	55C-F7462-00-P1	.BRACKET, FOOTREST 2	1				SMX
34	5BU-F7444-00	.COVER, REAR FOOTREST	1				
35	5BU-F7445-00	.PLATE 1	1				
36	91701-08042	.PIN	1				
37	90252-23800	.PIN, COTTER	1				
38	5TF-F7314-00	.STOPPER	1				
39	90110-08199	BOLT, HEXAGON SOCKET HEAD	2				
40	5TF-F7424-00	DAMPER, FOOTREST 2	1				
41	90387-10805	COLLAR	1				

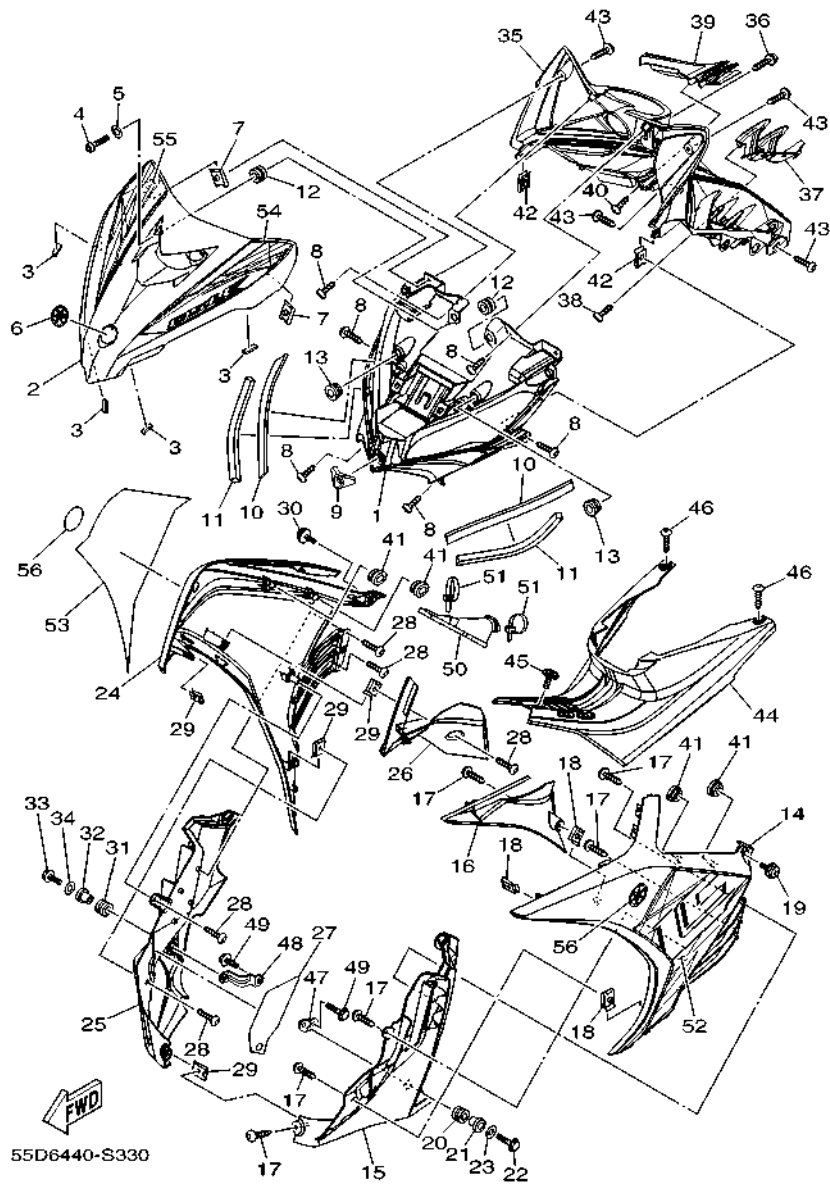


55D6440-S330

FIG. 33 LEG SHIELD

REF. NO.	PART NO.	DESCRIPTION	55D7	REMARKS
1	55D-F3391-00	PANEL, FRONT	1	
2	55D-F8345-10-P0	MOLE 1	1	UR FOR RM7
	55D-F8345-10-P3	MOLE 1	1	UR MBL2 FOR SMX
	55D-F8345-10-P2	MOLE 1	1	UR VPBC5 FOR S3
	55D-F8345-10-P1	MOLE 1	1	UR SMX FOR MS1
3	55C-F844E-00	SEAL 3	4	
4	92017-06012	BOLT, BUTTON HEAD	2	
5	90201-06822	WASHER, PLATE	2	
6	5VW-F313B-00	EMBLEM, 1	1	
7	90183-05807	NUT, SPRING	2	
8	97707-50014	SCREW, TRUSS HEAD TAPPING	6	
9	55D-F8187-00	GROMMET	1	
10	90520-05806	DAMPER, PLATE	2	
11	90520-10810	DAMPER, PLATE	2	
12	90480-13807	GROMMET	2	
13	90480-13867	GROMMET	2	
14	55C-F8311-00-P2	LEG SHIELD 1	1	UR FOR RM7
	55C-F8311-00-P0	LEG SHIELD 1	1	UR FOR SMX
	55C-F8311-00-P4	LEG SHIELD 1	1	UR FOR S3
	55C-F8311-00-P7	LEG SHIELD 1	1	UR FOR MS1
15	55C-F835J-00	BODY, FRONT UNDER 1	1	
16	55C-F137U-00	GUIDE, AIR 1	1	
17	97707-50014	SCREW, TRUSS HEAD TAPPING	6	
18	90183-05807	NUT, SPRING	3	
19	90159-06181	SCREW, WITH WASHER	1	
20	90480-18418	GROMMET	1	
21	90387-09801	COLLAR	1	



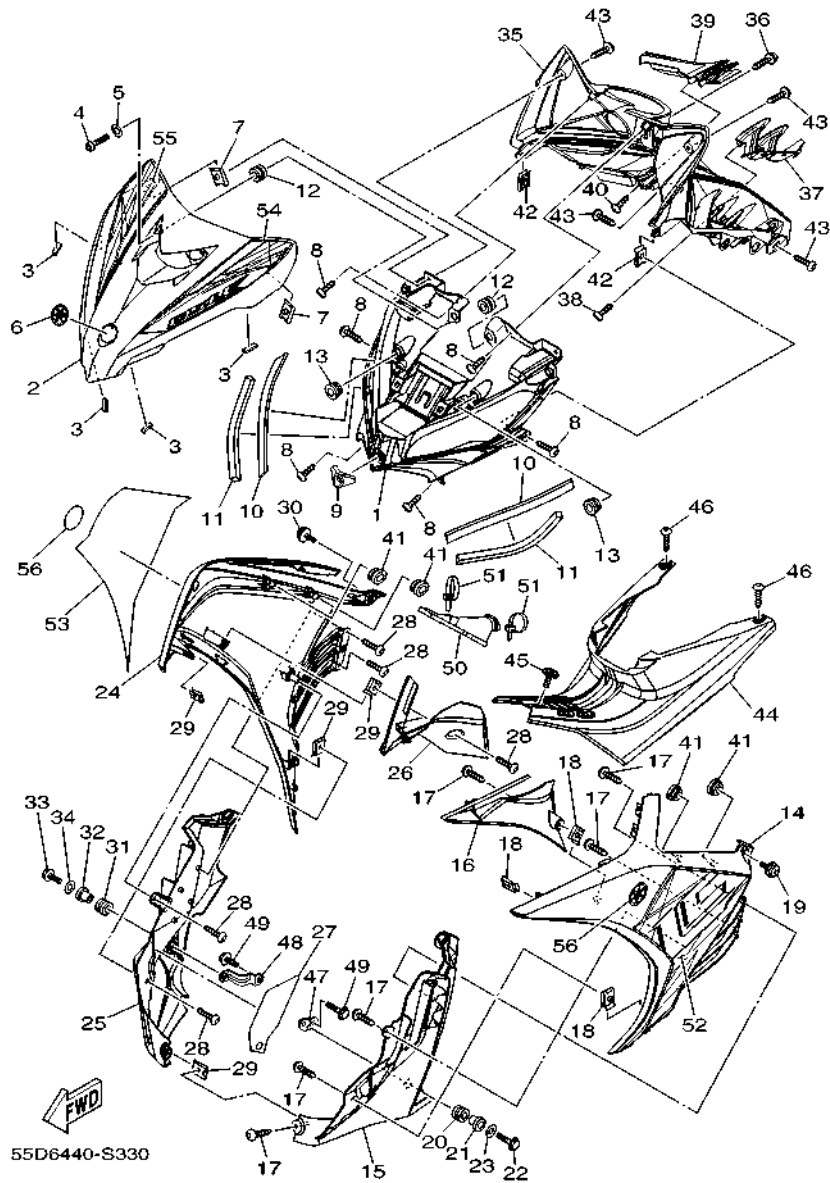


55D6440-S330

FIG. 33 LEG SHIELD

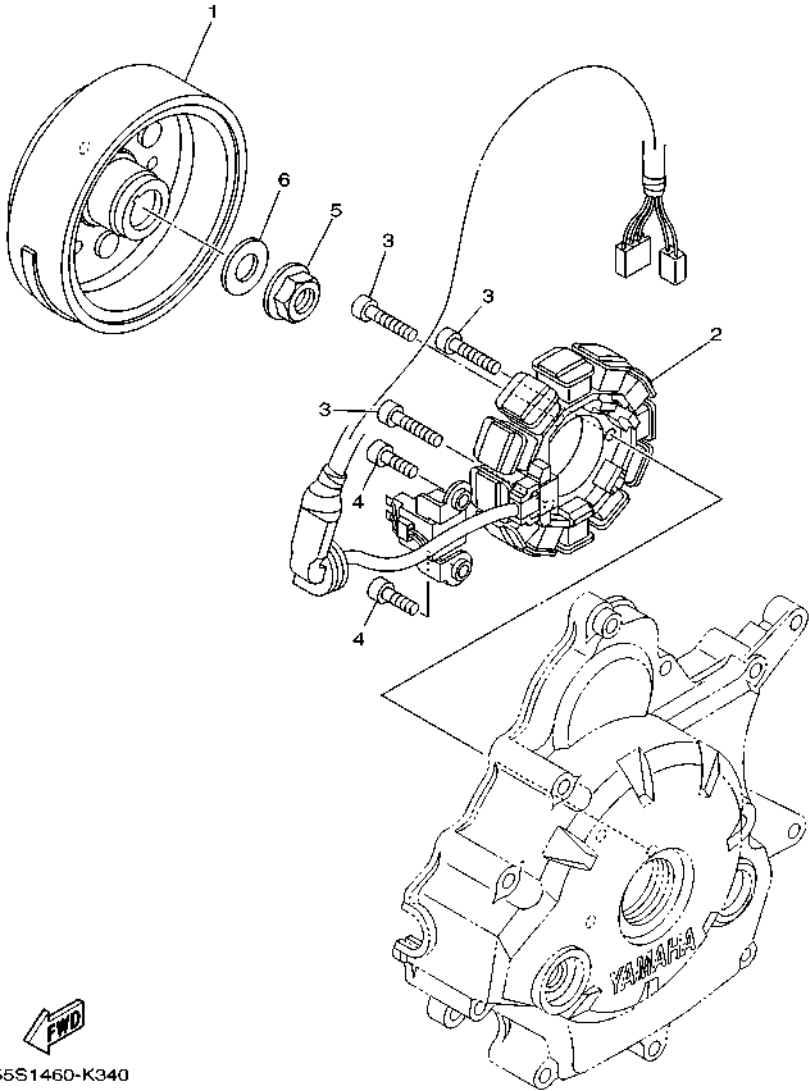
REF. NO.	PART NO.	DESCRIPTION	55D7	REMARKS
22	95807-06020	BOLT, FLANGE	1	
23	90201-06557	WASHER, PLATE	1	
24	55C-F8312-00-P2	LEG SHIELD 2	1	UR FOR RM7
	55C-F8312-00-P0	LEG SHIELD 2	1	UR FOR SMX
	55C-F8312-00-P4	LEG SHIELD 2	1	UR FOR S3
	55C-F8312-00-P7	LEG SHIELD 2	1	UR FOR MS1
25	55C-F835K-00	BODY, FRONT UNDER 2	1	
26	55C-F137V-00	GUIDE, AIR 2	1	
27	50C-F8307-00	SEAL	1	
28	97707-50014	SCREW, TRUSS HEAD TAPPING	5	
29	90183-05807	NUT, SPRING	4	
30	90159-06181	SCREW, WITH WASHER	1	
31	90480-18418	GROMMET	1	
32	90387-09801	COLLAR	1	
33	95807-06020	BOLT, FLANGE	1	
34	90201-06557	WASHER, PLATE	1	
35	55C-F836K-00	PANEL, INNER 1	1	
36	90159-06181	SCREW, WITH WASHER	1	
37	55C-F8273-00	FIN 1	1	
38	97707-50012	SCREW, TRUSS HEAD TAPPING	2	
39	55C-F8274-00	FIN 2	1	
40	97707-50012	SCREW, TRUSS HEAD TAPPING	2	
41	90480-01813	GROMMET	4	
42	90183-05807	NUT, SPRING	2	
43	97707-50014	SCREW, TRUSS HEAD TAPPING	4	
44	55C-F842N-00	COVER 2	1	
45	90159-06181	SCREW, WITH WASHER	1	

**FIG. 33 LEG SHIELD**



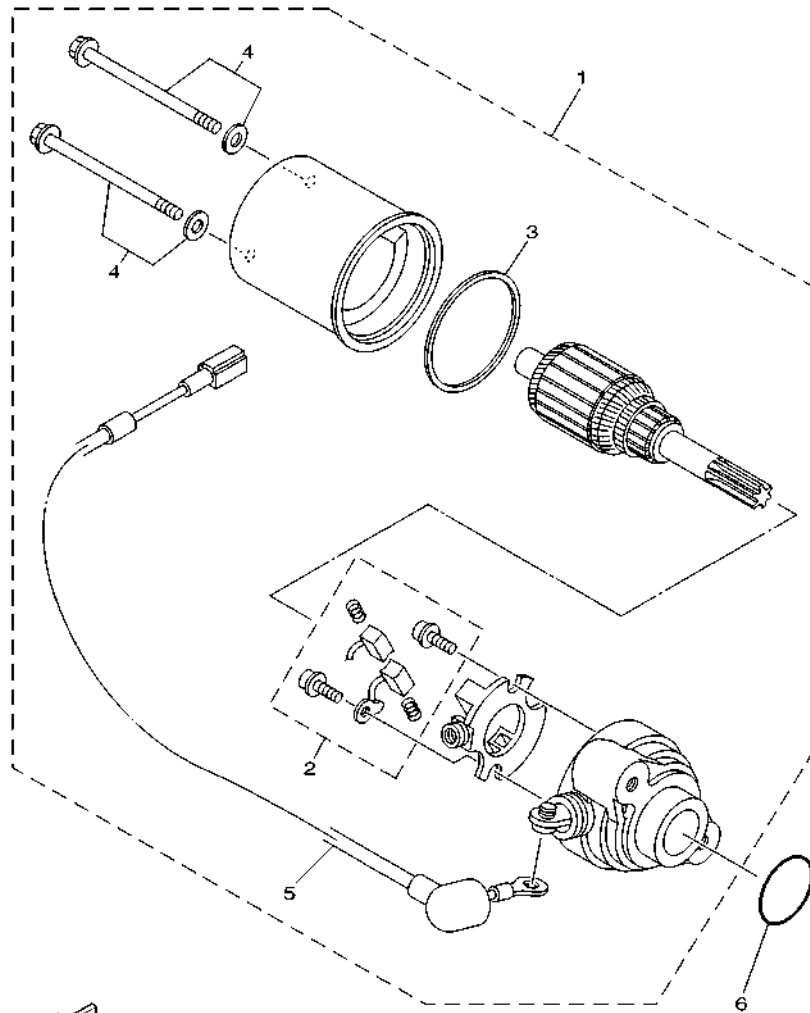
REF. NO.	PART NO.	DESCRIPTION	55D7	REMARKS
46	97707-50014	SCREW, TRUSS HEAD TAPPING	2	
47	55D-F8321-00	STAY 1	1	
48	55D-F8322-00	STAY 2	1	
49	95807-06020	BOLT, FLANGE	2	
50	1S8-F8336-00	PLATE	1	
51	90464-50801	CLAMP	2	
52	55D-F8391-E0	GRAPHIC 1	1	UR FOR RM7
	55D-F8391-F0	GRAPHIC 1	1	UR FOR SMX
	55D-F8391-G0	GRAPHIC 1	1	UR FOR S3
	55D-F8391-H0	GRAPHIC 1	1	UR FOR MS1
53	55D-F8392-E0	GRAPHIC 2	1	UR FOR RM7
	55D-F8392-F0	GRAPHIC 2	1	UR FOR SMX
	55D-F8392-G0	GRAPHIC 2	1	UR FOR S3
	55D-F8392-H0	GRAPHIC 2	1	UR FOR MS1
54	55D-F8393-E0	GRAPHIC 3	1	UR FOR RM7
	55D-F8393-F0	GRAPHIC 3	1	UR FOR SMX
	55D-F8393-G0	GRAPHIC 3	1	UR FOR S3
	55D-F8393-H0	GRAPHIC 3	1	UR FOR MS1
55	55D-F8394-E0	GRAPHIC 4	1	UR FOR RM7
	55D-F8394-F0	GRAPHIC 4	1	UR FOR SMX
	55D-F8394-G0	GRAPHIC 4	1	UR FOR S3
	55D-F8394-H0	GRAPHIC 4	1	UR FOR MS1
56	29B-F411B-00	EMBLEM	2	

**FIG. 34 GENERATOR**



55S1460-K340

REF. NO.	PART NO.	DESCRIPTION	55D7			REMARKS
1	55S-H1450-00	ROTOR ASSY	1			
2	1S7-H1410-01	STATOR ASSY	1			
3	91317-06025	BOLT,HEX.SOCKET HEAD	3			
4	91317-06016	BOLT,HEX.SOCKET HEAD	2			
5	95707-12500	NUT, FLANGE	1			
6	90201-122H1	WASHER, PLATE	1			

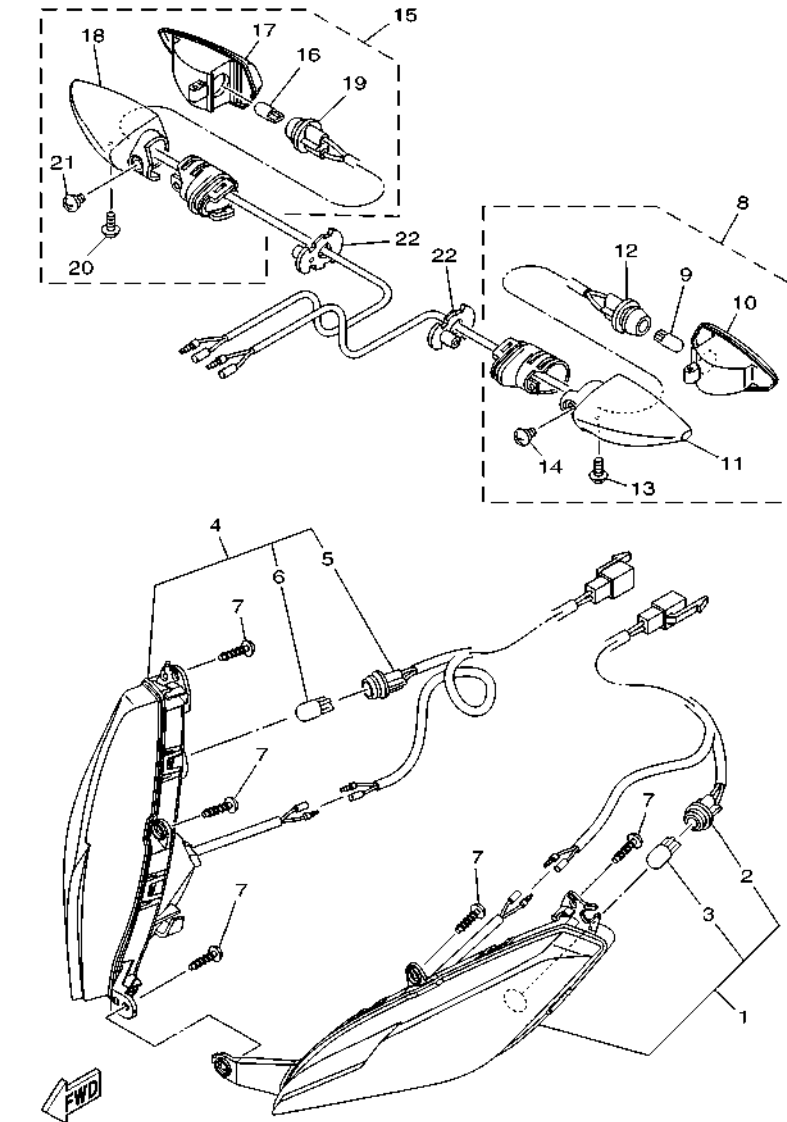


  
 1S9A422-K350

**FIG. 35 STARTING MOTOR**

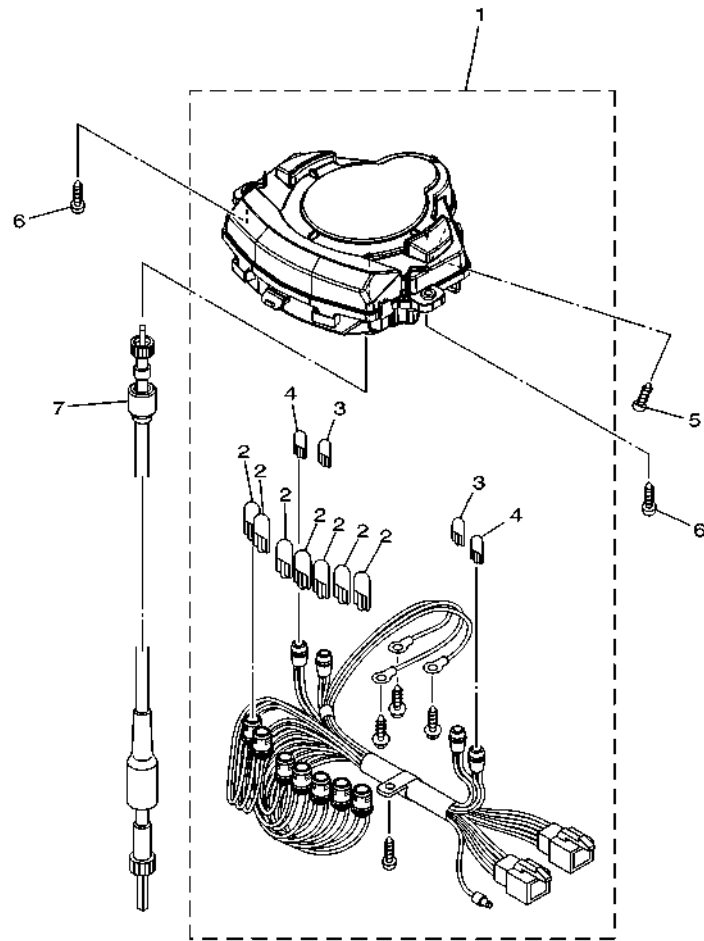
REF. NO.	PART NO.	DESCRIPTION	55D7	REMARKS
1	1S7-H1800-02	STARTING MOTOR ASSY	1	
2	3AY-H1801-00	.BRUSH SET	1	
3	1S7-H1861-00	.GASKET	1	
4	3AY-H1828-00	.SCREW 2	2	
5	5YP-H183G-00	.CORD COMP.	1	
6	93210-26801	O-RING	1	

**FIG. 36 FLASHER LIGHT**



55D5440-R360

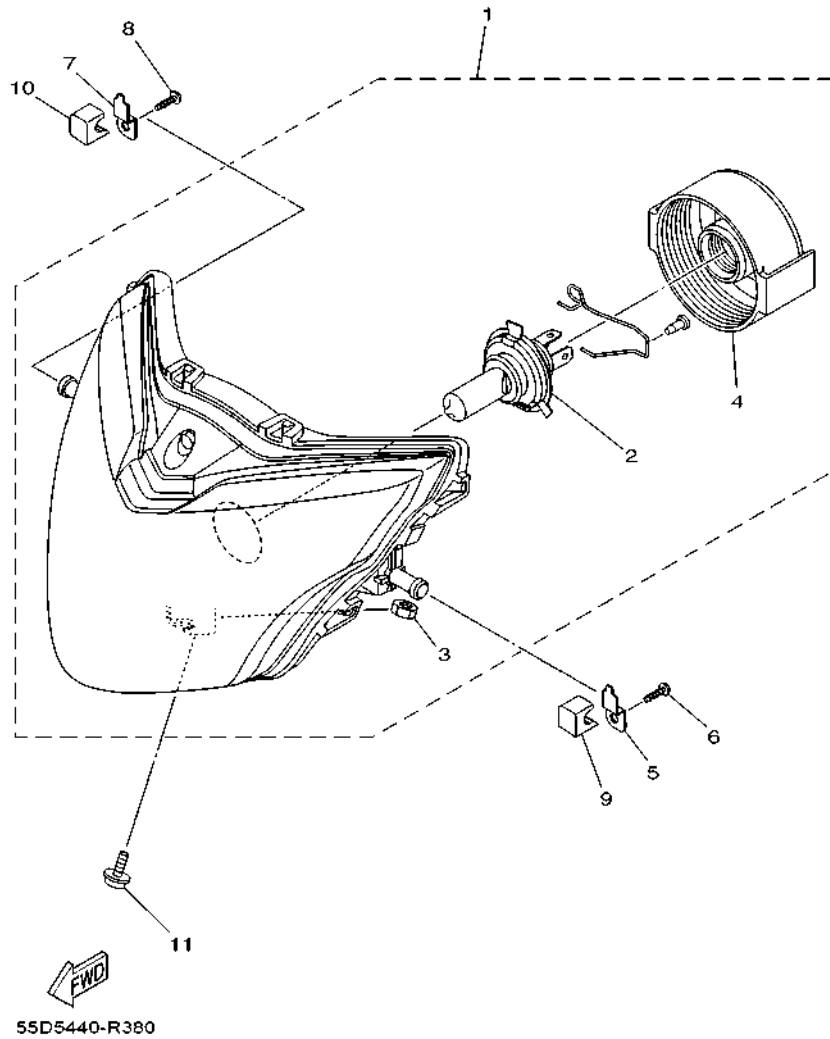
REF. NO.	PART NO.	DESCRIPTION	55D7				REMARKS
1	55D-H3310-20	FRONT FLASHER LIGHT ASSY 1	1				
2	55D-H3336-20	.CORD	1				
3	55D-H3311-00	.BULB, FLASHER (12V-10W)	1				
4	55D-H3320-20	FRONT FLASHER LIGHT ASSY 2	1				
5	55D-H3346-20	.CORD	1				
6	55D-H3311-00	.BULB, FLASHER (12V-10W)	1				
7	97707-50016	SCREW, TRUSS HEAD TAPPING	5				
8	55D-H3330-01	REAR FLASHER LIGHT ASSY 1	1				
9	55D-H3311-00	.BULB, FLASHER (12V-10W)	1				
10	55D-H333A-00	.LENS COMP 1	1				
11	55D-H3323-00	.BODY	1				
12	55D-H333E-01	.CORD ASSY	1				
13	55D-H3333-00	.SCREW, LENS FITTING	1				
14	55D-H3358-00	.SCREW, SPECIAL	1				
15	55D-H3340-01	REAR FLASHER LIGHT ASSY 2	1				
16	55D-H3311-00	.BULB, FLASHER (12V-10W)	1				
17	55D-H334A-00	.LENS COMP 2	1				
18	55D-H332M-00	.BODY 2	1				
19	55D-H334E-01	.CORD ASSY	1				
20	55D-H3333-00	.SCREW, LENS FITTING	1				
21	55D-H3358-00	.SCREW, SPECIAL	1				
22	1VP-H3318-00	STAY, FLASHER 1	2				



  
 55D1440-K370

**FIG. 37 METER**

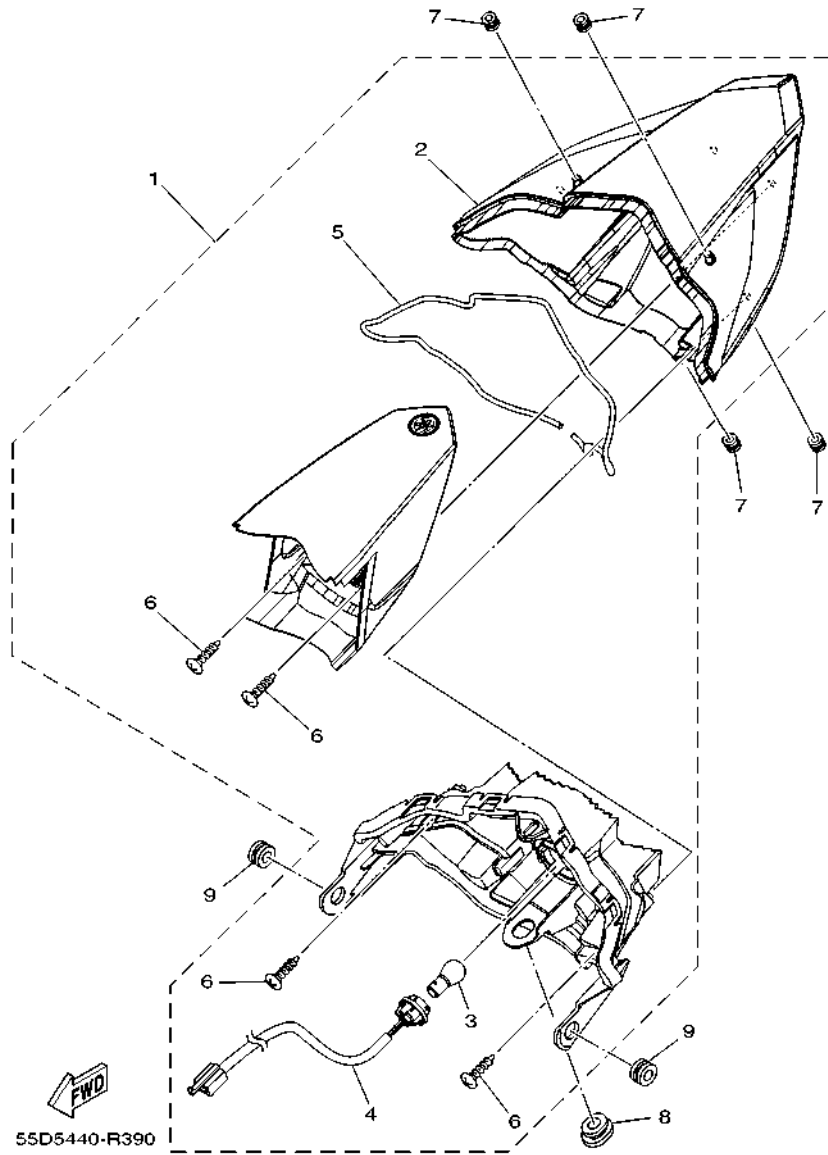
REF. NO.	PART NO.	DESCRIPTION	55D7				REMARKS
1	55D-H3510-20	SPEEDOMETER ASSY	1				
2	5LW-H3518-00	.BULB, METER (T10 12V-1.7W)	7				
3	5BU-H3517-10	.BULB (T6.5 12V-1.7W)	2				
4	55D-H3519-00	.BULB, METER (T6.5 14V-3W)	2				
5	97707-50016	SCREW, TRUSS HEAD TAPPING	1				
6	97707-50025	SCREW, TAPPING	2				
7	55C-H3550-10	SPEEDOMETER CABLE ASSY	1				



**FIG. 38 HEADLIGHT**

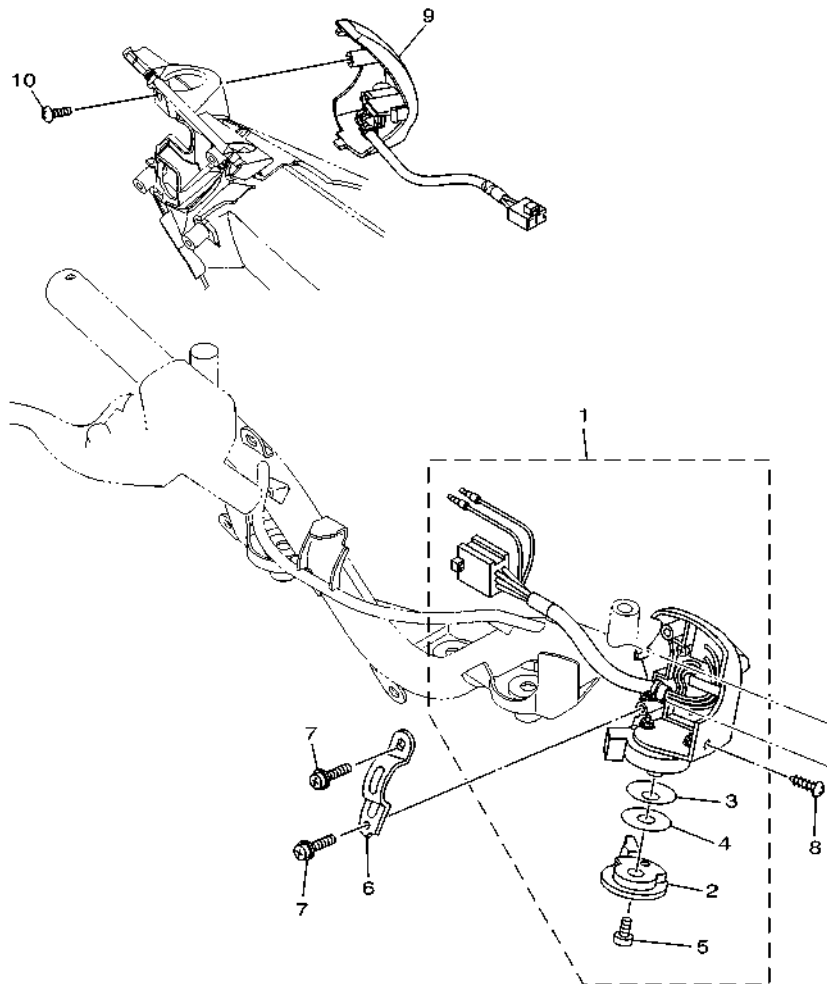
REF. NO.	PART NO.	DESCRIPTION	55D7	REMARKS
1	55D-H4310-00	HEADLIGHT UNIT ASSY	1	
2	1VP-H4314-00	.BULB, HEADLIGHT (12V 35/35W)	1	
3	90173-06015	.NUT, SQUARE	1	
4	1VP-H4397-00	.COVER, SOCKET	1	
5	55C-H4781-00	BRACKET 1	1	
6	97707-50016	SCREW, TRUSS HEAD TAPPING	1	
7	55C-H4782-00	BRACKET 2	1	
8	97707-50016	SCREW, TRUSS HEAD TAPPING	1	
9	55C-H411T-00	HOLDER, 1	1	
10	55C-H411U-00	HOLDER, 2	1	
11	95807-06010	BOLT, FLANGE	1	

**FIG. 39 TAILLIGHT**



REF. NO.	PART NO.	DESCRIPTION	55D7				REMARKS
1	55D-H4710-00	TAILLIGHT UNIT ASSY	1				
2	55D-H4721-10	.LENS, TAILLIGHT	1				
3	1VP-H4714-00	.BULB, TAILLIGHT (12V-21/5W)	1				
4	55D-H4735-10	.SOCKET CORD ASSY	1				
5	55D-H4723-10	.GASKET, TAIL LENS	1				
6	97707-40616	.SCREW, TAPPING	4				
7	55C-H4759-00	GROMMET	4				
8	90480-01868	GROMMET	1				
9	90480-13807	GROMMET	2				

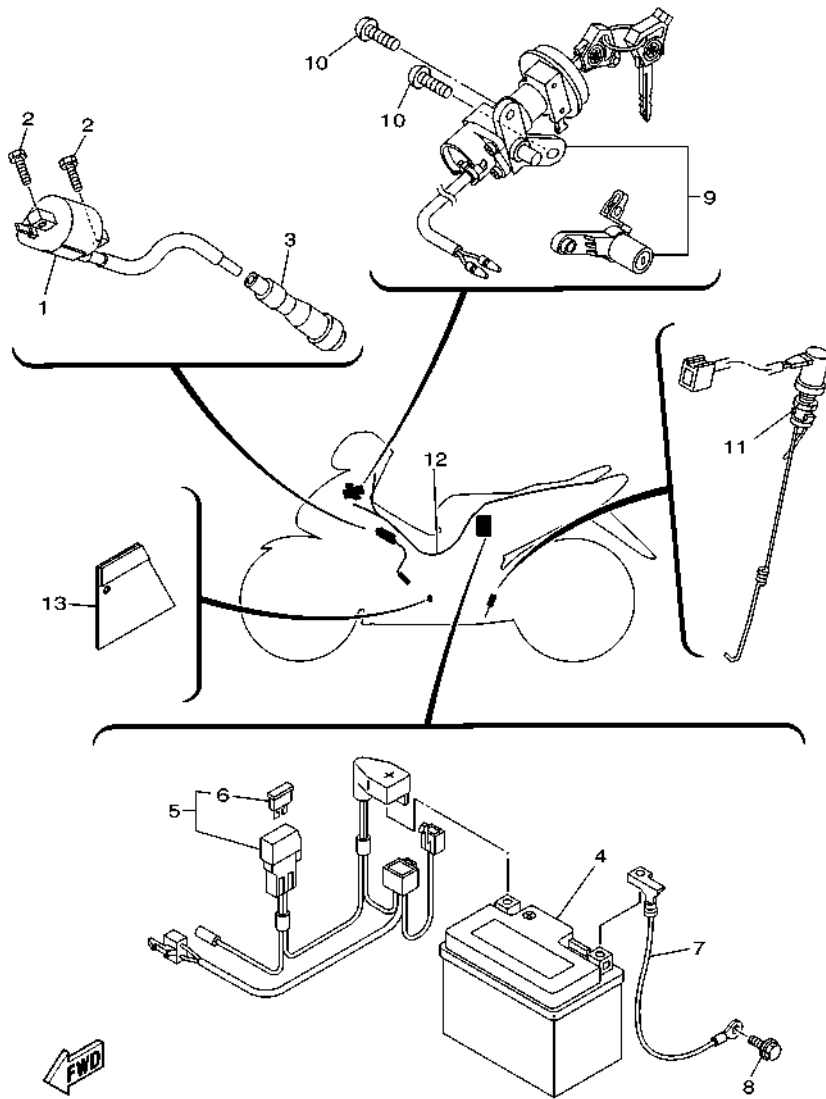




  
 55D7440-T400

**FIG. 40 HANDLE SWITCH & LEVER**

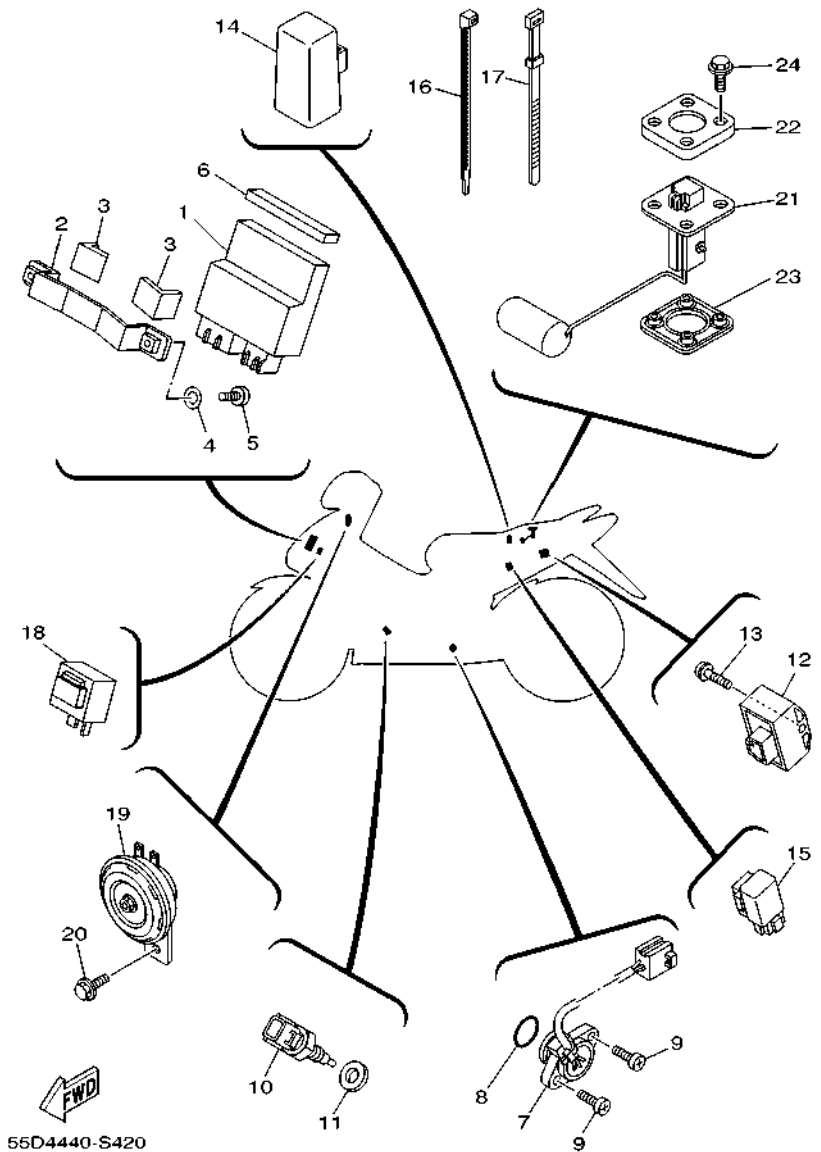
REF. NO.	PART NO.	DESCRIPTION	55D7				REMARKS
1	1S8-H3973-02	SWITCH, HANDLE 3	1				
2	1S8-H3941-00	.LEVER, STARTER	1				
3	1S8-H3947-00	.SPRING	1				
4	1S8-H397X-00	.SPACER	1				
5	9850L-06008	.SCREW, PAN HEAD	1				
6	1S8-H3955-01	BRACKET 1	1				
7	97607-05216	SCREW, WITH WASHER	2				
8	97707-50012	SCREW, TRUSS HEAD TAPPING	1				
9	1KP-H3976-00	SWITCH, HANDLE 1	1				
10	97707-50012	SCREW, TRUSS HEAD TAPPING	1				



50C1460-K430

FIG. 41 ELECTRICAL 1

REF. NO.	PART NO.	DESCRIPTION	55D7				REMARKS
1	4US-H2310-20	IGNITION COIL ASSY	1				
2	97007-06016	BOLT	2				
3	55D-H2370-00	PLUG CAP ASSY	1				
4	10C-H2100-02	BATTERY ASSY (YUASA YTZ5S)	1				UR
	55D-H2100-00	BATTERY ASSY (PINACO PTZ5S)	1				UR
5	55C-H2150-10	FUSE HOLDER ASSY	1				
6	31D-H2151-00	.FUSE (7.5A)	1				
7	55C-H2116-00	WIRE, MINUS LEAD	1				
8	95027-06010	BOLT, FLANGE	1				
9	55C-XH252-00	MAIN SWITCH SUB ASSY.	1				
10	90149-06309	SCREW	2				
11	1S9-H2530-12	STOP SWITCH ASSY	1				
12	55D-H2590-20	WIRE HARNESS ASSY	1				
13	1S8-F117F-00	COVER	1				



55D4440-S420

FIG. 42 ELECTRICAL 2

REF. NO.	PART NO.	DESCRIPTION	55D7				REMARKS
1	55D-H5540-10	C.D.I. UNIT ASSY	1				
2	55C-F8426-00	BRACKET 1	1				
3	90520-04804	DAMPER, PLATE	2				
4	90201-06830	WASHER, PLATE	2				
5	98507-06012	SCREW, PAN HEAD	2				
6	90520-96802	DAMPER, PLATE	1				
7	5YP-H2540-00	NEUTRAL SWITCH ASSY	1				
8	93210-21800	O-RING	1				
9	98507-05016	SCREW, PAN HEAD	2				
10	5YP-85790-00	THERMOSENSOR ASSY	1				
11	90430-12801	GASKET	1				
12	2LP-H1960-00	RECTIFIER & REGULATOR ASSY	1				
13	97607-06212	SCREW, WITH WASHER	1				
14	5TP-H1940-00	STARTER RELAY ASSY	1				
15	5YP-H1950-00	RELAY ASSY	1				
16	90464-50800	CLAMP	5				
17	3AY-H3936-10	BAND, SWITCH CORD	1				
18	1VP-83350-00	FLASHER RELAY ASSY	1				
19	55D-H3371-00	HORN	1				
20	95807-08012	BOLT, FLANGE	1				
21	1S8-H5752-00	SENDER UNIT ASSY, FUEL METER	1				
22	5BU-H5757-00	RETAINER	1				
23	5BU-H5753-01	GASKET, SENDER UNIT	1				
24	90119-05071	BOLT, WITH WASHER	4				

NUMERICAL INDEX

PART NO.	REF. NO.	PART NO.	REF. NO.	PART NO.	REF. NO.	PART NO.	REF. NO.	PART NO.	REF. NO.	PART NO.	REF. NO.
1S8-11633-01	2 - 10	2PV-E1193-00	1 - 14	2S5-E3447-00	7 - 9	1S9-E5661-00	13 - 1	5YP-E8140-00	18 - 7	1S8-F172L-00	21 - 23
1S8-11681-01	2 - 3	1S7-E1196-00	5 - 5	5MX-E3474-01	8 - 10	5YP-E5664-00	13 - 4	5YP-E8172-00	18 - 3	5YP-F172M-00	21 - 24
5YP-12117-00	3 - 6	50C-E1311-00	1 - 23	5MX-E3474-01	8 - 2	5YP-E5671-00	13 - 3	1S8-E8173-00	18 - 16	1S8-F172W-00	21 - 26
1WG-12118-00	3 - 5	55D-E1351-00	1 - 24	1S7-E3542-00	8 - 4	5YP-E5674-00	13 - 9	1S7-E8175-00	18 - 9	55C-F1731-00-P0	21 - 6
5YP-12411-00	6 - 1	1S8-E1422-00	2 - 6	5MX-E3575-01	8 - 22	5YP-E5696-00	13 - 7	5YP-E8179-00	18 - 2	55C-F1731-00-P4	21 - 6
5LW-14103-00	9 - 27	50C-E1603-00	2 - 12	55P-E3586-00	8 - 3	5YP-E5767-00	13 - 5	1S8-E817A-00	18 - 17	55C-F1731-00-P5	21 - 6
50C-14105-00	9 - 29	2S6-E1631-21	2 - 9	55C-E4197-00	8 - 8	5YP-E6116-00	15 - 1	5YP-E8181-00	18 - 4	55C-F1741-00-P0	21 - 10
31S-14112-00	9 - 4	1S8-E1651-00	2 - 5	1S8-E4293-00	21 - 36	5YP-E6131-00	15 - 4	5YP-E8185-00	17 - 2	55C-F1741-00-P4	21 - 10
509-14135-00	9 - 25	50C-E1951-00	5 - 8	50C-E4411-00	8 - 11	1S8-E6135-00	15 - 29	5YP-E8186-00	18 - 18	55C-F1741-00-P5	21 - 10
50C-14137-00	9 - 39	1S7-E1952-01	5 - 9	1S7-E4412-00	8 - 12	5YP-E6143-00	15 - 13	5YP-E8337-00	18 - 10	55D-F174G-D0	21 - 37
5P0-14141-13	9 - 37	2PV-E2111-00	3 - 1	1S7-E4425-00	8 - 21	5YP-E6144-00	15 - 7	5YP-E8511-00	17 - 11	55D-F174G-E0	21 - 37
5P0-14142-15	9 - 30	5YP-E2113-00	3 - 4	1S7-E4437-00	8 - 18	5YP-E6150-00	15 - 18	5YP-E8512-00	17 - 12	55D-F174G-F0	21 - 37
5HK-14147-00	9 - 11	5YP-E2119-00	3 - 3	5TL-E443E-00	8 - 16	1S8-E6181-00	15 - 17	1S8-E8531-00	17 - 9	55D-F174G-G0	21 - 37
5LW-14147-00	9 - 36	2PV-E2121-00	3 - 2	1S7-E4450-00	8 - 13	5YP-E6182-00	15 - 2	5YP-E8540-00	17 - 1	55D-F174H-D0	21 - 38
5FC-14149-00	9 - 35	5YP-E2126-00	3 - 7	1S7-E4452-00	8 - 15	5YP-E6321-00	15 - 21	4TT-E8542-00	17 - 6	55D-F174H-E0	21 - 38
5LW-14150-00	9 - 12	5YP-E2151-00	3 - 8	50C-E4453-00	8 - 14	5YP-E6324-00	15 - 20	5TN-E8545-00	16 - 16	55D-F174H-F0	21 - 38
5LW-14171-10	9 - 38	1S8-E2156-00	3 - 14	1S8-E4613-00	10 - 5	5YP-E6331-00	15 - 22	5YP-E8549-00	17 - 3	55D-F174H-G0	21 - 38
22F-14173-00	9 - 28	5YP-E2157-00	4 - 7	55D-E4703-10	10 - 1	5YP-E6333-00	15 - 26	5YP-E8561-00	16 - 15	55D-F174J-80	21 - 39
3RW-14174-00	9 - 23	5YP-E2159-00	3 - 9	55D-E4718-10	10 - 2	5HV-E6346-00	18 - 21	55D-F1110-20	19 - 1	55D-F174J-90	21 - 39
353-14186-00	9 - 13		3 - 12	29B-E4747-00	10 - 12	5YP-E6351-00	15 - 25	55C-F1161-10	23 - 13	55D-F174J-A0	21 - 39
5MP-14191-00	9 - 21	5YP-E2161-00	3 - 11	55D-E4799-10	10 - 3	5YP-E6356-00	15 - 32	55P-F1173-00	21 - 25	55D-F174J-B0	21 - 39
3G2-14231-23	9 - 10	21S-E2170-01	4 - 1	5YP-E4840-00	1 - 9	5YP-E6357-00	15 - 31	1S8-F117F-00	41 - 13	55D-F174K-80	21 - 40
4JG-14261-00	9 - 31	5MX-E2210-00	4 - 15	1S7-E4877-01	8 - 32	5YP-E6371-00	15 - 19	1S8-F117G-00	19 - 15	55D-F174K-90	21 - 40
50C-14261-00	9 - 5	1S8-E2213-01	4 - 17	5YP-E4881-00	8 - 35	5YP-E6383-00	15 - 23	55C-F117K-00	26 - 16	55D-F174K-A0	21 - 40
5HK-14275-00	9 - 33	5MX-E2222-00	4 - 16	55C-E4882-00	8 - 28	5YP-E6384-00	15 - 24	1S8-F1315-00	19 - 10	55D-F174K-B0	21 - 40
33S-14280-00	9 - 32	1S8-E2231-00	4 - 11	5YP-E4890-00	1 - 10	5YP-E6512-00	15 - 11	1S8-F1316-00	19 - 11	55C-F177G-00	21 - 31
5YP-14429-00	9 - 9	5YP-E2241-00	4 - 12	55D-E4901-10	9 - 1	5YP-E6539-00	15 - 5	55C-F137U-00	33 - 16	55C-F1817-00	21 - 28
5YP-14561-00	9 - 20	1B9-E2280-02	4 - 5	5YP-E5113-00	12 - 11	5YP-E6586-00	15 - 12	55C-F137V-00	33 - 26	1S9-F1871-01	21 - 17
50C-14589-00	9 - 6	5YP-E2288-00	4 - 6	1S8-E5150-00	11 - 1	5YP-E6611-00	15 - 3	1S8-F139R-00	19 - 12	5YP-F1875-00	21 - 22
5YP-1482K-00	1 - 8	5YP-E2405-00	6 - 6	1S8-E5351-00	7 - 4	5YP-E6620-00	15 - 9	1S8-F139X-00	19 - 13	55D-F2110-00	22 - 1
55D-1490J-00	9 - 7	1S8-E2413-00	6 - 2	1S8-E5362-00	12 - 22	5YP-E6628-00	15 - 28	55C-F1511-00-P2	20 - 1	4UL-F2123-00	22 - 2
5AP-14940-00	9 - 34	1S7-E2422-00	5 - 1	5YP-E5377-00	12 - 16	5YP-E6777-00	15 - 27	55C-F1511-00-P7	20 - 1	50C-F2141-00	22 - 6
5LW-14958-00	9 - 3	50C-E2428-00	5 - 3	55D-E5411-00	12 - 1	5YP-E7121-00	16 - 6	55C-F1511-00-P8	20 - 1	1S8-F2151-00	22 - 3
5HK-14985-00	9 - 15	1S8-E2443-01	6 - 13	55D-E5418-00	12 - 12	5YP-E7131-00	16 - 2	55C-F1511-00-P9	20 - 1	55C-F2210-00	22 - 11
5LW-14994-00	9 - 19	1S7-E2450-00	5 - 7	55D-E5421-00	12 - 17	5YP-E7141-00	16 - 3	15K-F1518-00	20 - 5	55D-F3100-10	24 - 1
50C-14995-00	9 - 24	5YP-E2461-00	6 - 5	55D-E5451-00	12 - 2	5YP-E7211-00	16 - 22	55C-F160E-00	20 - 12	55C-F3110-00	24 - 8
5LW-24411-00	9 - 2	1S8-E2481-00	6 - 15	55D-E5461-00	12 - 18	5YP-E7221-00	16 - 14	55C-F1611-10	20 - 6	4VK-F3111-10	24 - 19
4X8-24512-00	25 - 14	1S8-E2482-00	6 - 17	5YP-E5514-00	14 - 1	5YP-E7231-00	16 - 21	55D-F1650-00	22 - 8	55P-F3126-10	24 - 5
3T5-24612-20	25 - 18	5YP-E2491-00	6 - 3	1S8-E5521-00	14 - 2	5YP-E7241-00	16 - 20	55C-F1711-00-P0	21 - 1	55P-F3136-10	24 - 2
1VP-83350-00	42 - 18	5YP-E2576-00	6 - 19	55D-E5524-00	14 - 3	5YP-E7411-00	16 - 1	55C-F1711-00-P2	21 - 1	5VW-F313B-00	33 - 6
5YP-85790-00	42 - 10	5P0-E2590-00	6 - 9	5YP-E5555-00	13 - 8	5YP-E7421-00	16 - 13	55C-F1711-00-P3	21 - 1	50C-F3141-00	24 - 15
1S8-E1102-00	1 - 1	5YP-E2671-00	6 - 8	1ST-E5580-00	14 - 5	1S8-E7456-00	16 - 29	55C-F1711-00-PA	21 - 1	5LL-F3144-00	24 - 14
1S8-E111F-00	4 - 8	5YP-E2675-00	6 - 7	1ST-E5583-00	14 - 6	1S8-E7471-00	16 - 11	55C-F1721-00-P0	21 - 3	4UV-F3145-00	24 - 3
5YP-E1133-10	1 - 2	1S7-E3300-00	7 - 1	1S8-E5598-00	4 - 14	5YP-E8101-00	18 - 1	55C-F1721-00-P2	21 - 3		24 - 6
55P-E1166-00	8 - 25	1S8-E3327-00	7 - 12	1ST-E5614-00	14 - 7	55D-E8110-10	18 - 22	55C-F1721-00-P3	21 - 3	2JG-F3147-00	24 - 20
1S8-E1181-01	1 - 19	1S8-E3329-00	7 - 2	2N9-E5618-00	13 - 12	5H3-E8113-00	18 - 23	55C-F1721-00-PA	21 - 3	5TF-F3152-00	24 - 11
1S7-E1185-01	5 - 4	1S8-E3411-00	7 - 5	1S8-E5620-00	13 - 11	5YP-E8120-00	17 - 8	55C-F172E-00	21 - 15	5P0-F3156-00	24 - 4
1S8-E1191-00	1 - 6	38B-E3440-00	7 - 8	5YP-E5641-00	13 - 2	5YP-E8127-00	18 - 6	5YP-F172K-00	21 - 19		24 - 7

NUMERICAL INDEX

PART NO.	REF. NO.	PART NO.	REF. NO.	PART NO.	REF. NO.	PART NO.	REF. NO.	PART NO.	REF. NO.	PART NO.	REF. NO.
2JG-F3157-00	24 - 10	1S8-F5338-00-P2	29 - 1	5P2-F6281-00	30 - 33	55C-F835J-00	33 - 15	55D-H3311-00	36 - 16	55D-H5130-00	20 - 9
509-F3158-L0	24 - 12	5LW-F533A-00	29 - 12	5P2-F6282-00	30 - 34	55C-F835K-00	33 - 25	1VP-H3318-00	36 - 22	55D-H5540-10	42 - 1
5P2-F3170-00	24 - 9	4UV-F5351-00	29 - 13	5P2-F6282-00	30 - 24	55C-F836K-00	33 - 35	55D-H3320-20	36 - 4	1S8-H5752-00	42 - 21
31D-F3181-50	24 - 13	1S8-F5355-00	29 - 11	55C-F6301-10	30 - 25	55D-F8381-00	30 - 12	55D-H3323-00	36 - 11	5BU-H5753-01	42 - 23
55C-F331A-10	23 - 11	1S8-F5364-00	29 - 6	55C-F6326-00	30 - 4	55D-F8391-E0	33 - 52	55D-H332M-00	36 - 18	5BU-H5757-00	42 - 22
50C-F3340-10	24 - 16	1S8-F5366-00	29 - 15	55C-F6331-10	30 - 32	55D-F8391-F0	33 - 52	55D-H3330-01	36 - 8	18D-H5885-00	9 - 8
5YW-F3346-10	24 - 18	1S8-F5371-01	29 - 33	1S9-F6332-00	31 - 14	55D-F8391-G0	33 - 52	55D-H3333-00	36 - 13	1S9-W0041-00	31 - 16
55C-F3389-00	23 - 15	55D-F5377-00	29 - 30	55D-F7111-00	32 - 1	55D-F8391-H0	33 - 52		36 - 20	4C9-W0048-00	28 - 8
55D-F3391-00	33 - 1	55S-F5381-00	29 - 25	5YP-F7112-00	32 - 3	55D-F8392-E0	33 - 53	55D-H3336-20	36 - 2	1S8-WE140-11	2 - 1
156-F3411-00	24 - 17	55D-F5383-00	29 - 27	1S8-F7114-00	32 - 2	55D-F8392-F0	33 - 53	55D-H333A-00	36 - 10	1S8-WE141-00	2 - 2
4RT-F3411-10	23 - 4	50C-F5388-00	29 - 28	55D-F7211-00	32 - 9	55D-F8392-G0	33 - 53	55D-H333E-01	36 - 12	55C-XH252-00	41 - 9
1KL-F3412-10	23 - 1	50C-F5389-00	29 - 29	55S-F7231-00	32 - 11	55D-F8392-H0	33 - 53	55D-H3340-01	36 - 15	90101-06278	29 - 14
4RT-F3412-10	23 - 3	5XK-F5412-00	29 - 21	1S8-F7311-00	32 - 17	55D-F8393-E0	33 - 54	55D-H3346-20	36 - 5	90105-06061	8 - 7
5TL-F3416-00	23 - 6	3YR-F5439-10	29 - 19	5TF-F7314-00	32 - 30	55D-F8393-F0	33 - 54	55D-H334A-00	36 - 17	90105-06848	6 - 4
1P6-F341E-10	23 - 5	5P0-F5802-00	28 - 4		32 - 38	55D-F8393-G0	33 - 54	55D-H334E-01	36 - 19	90105-08850	1 - 16
5VL-F341E-10	23 - 2	5YP-F5803-50	28 - 5	1S8-F7411-00	32 - 21	55D-F8393-H0	33 - 54	55D-H3358-00	36 - 14	90105-088D8	19 - 5
55C-F3461-00	23 - 8	3C1-F5805-10	28 - 9	5LL-F7413-00	32 - 23	55D-F8394-E0	33 - 55		36 - 21	90105-088D9	19 - 4
1S8-F4110-00	25 - 1	44S-F580U-02	28 - 3	5TF-F7424-00	32 - 40	55D-F8394-F0	33 - 55	55D-H3371-00	42 - 19	90105-10036	23 - 9
29B-F411B-00	33 - 56	5P0-F5827-00	28 - 14	55C-F7430-00-P1	32 - 24	55D-F8394-G0	33 - 55	55D-H3510-20	37 - 1	90105-10323	22 - 12
21S-F4141-00	25 - 7	31D-F582U-00	28 - 1	5BU-F7433-00	32 - 26	55D-F8394-H0	33 - 55	5BU-H3517-10	37 - 3	90105-10831	28 - 15
55C-F4311-00	25 - 9	1S9-F583T-03	31 - 4	55C-F7440-00-P1	32 - 32	55C-F8426-00	42 - 2	5LW-H3518-00	37 - 2	90105-10861	19 - 3
55C-F4312-00	25 - 10	5HV-F5852-00	31 - 6	5BU-F7444-00	32 - 34	55C-F842N-00	33 - 44	55D-H3519-00	37 - 4	90109-06577	31 - 8
1S8-F4339-00	25 - 2	5HV-F5854-10	31 - 13	5BU-F7445-00	32 - 27	55C-F844E-00	33 - 3	55C-H3550-10	37 - 7	90109-08034	32 - 18
1S8-F4397-00	25 - 4	1S9-F585B-00	31 - 12		32 - 35	1S7-H1410-01	34 - 2	55C-H3559-00-P9	30 - 16	90109-08822	29 - 34
5YP-F4500-01	25 - 13	1S9-F5867-01	31 - 5	55C-F7452-00-P1	32 - 25	55S-H1450-00	34 - 1	1S9-H3922-01	31 - 7	90110-08199	32 - 31
5LW-F4610-01	25 - 17	50C-F5872-00	31 - 1	55C-F7462-00-P1	32 - 33	1S7-H1800-02	35 - 1	3AY-H3936-10	42 - 17		32 - 39
1S8-F4638-00	25 - 3	55C-F5875-10	23 - 17	55D-F8100-01	19 - 16	3AY-H1801-00	35 - 2	1S8-H3941-00	40 - 2	90111-06807	10 - 4
55D-F464U-00	26 - 25	55C-F5876-10	23 - 21	55D-F8187-00	33 - 9	3AY-H1828-00	35 - 4	1S8-H3947-00	40 - 3	90111-08853	28 - 2
55C-F470F-10	26 - 2	55P-F587A-00	23 - 19	1S8-F8217-00	30 - 6	5YP-H183G-00	35 - 5	1S8-H3955-01	40 - 6	90116-08017	29 - 20
5TF-F4723-00	26 - 3	5YP-F5917-00	28 - 6	1S8-F8227-00	30 - 7	1S7-H1861-00	35 - 3	1S8-H3973-02	40 - 1	90119-05071	42 - 24
55C-F4726-00	26 - 5	5P0-F5919-01	28 - 11	55C-F8273-00	33 - 37	5TP-H1940-00	42 - 14	1KP-H3976-00	40 - 9	90119-06044	20 - 7
2WB-F4727-00	26 - 9	5YP-F5924-00	28 - 12	55C-F8274-00	33 - 39	5YP-H1950-00	42 - 15	1S8-H397X-00	40 - 4		23 - 16
1S8-F4728-00	26 - 12	5YP-F5925-01	28 - 10	50C-F8307-00	33 - 27	2LP-H1960-00	42 - 12	18D-H3980-00	31 - 10	90119-06051	8 - 24
55C-F4730-10	26 - 1	5YP-F5937-00	28 - 7	55C-F8311-00-P0	33 - 14	55D-H2100-00	41 - 4	55C-H411T-00	38 - 9	90119-06137	21 - 18
4HF-F4741-00	26 - 4	5YP-F5939-00	28 - 13	55C-F8311-00-P2	33 - 14	10C-H2100-02	41 - 4	55C-H411U-00	38 - 10		21 - 34
1S8-F4742-00	26 - 6	55D-F6143-10-P0	30 - 8	55C-F8311-00-P4	33 - 14	55C-H2116-00	41 - 7	55D-H4310-00	38 - 1	90119-06190	25 - 6
55D-F4742-00	26 - 22	55D-F6143-10-P1	30 - 8	55C-F8311-00-P7	33 - 14	5VW-H2131-00	21 - 35	1VP-H4314-00	38 - 2	90149-06011	25 - 15
1S8-F4768-00	26 - 27	55D-F6143-10-P2	30 - 8	55C-F8312-00-P0	33 - 24	55C-H2150-10	41 - 5	1VP-H4397-00	38 - 4	90149-06309	41 - 10
55D-F4773-00-P3	26 - 19	55C-F6145-00	30 - 15	55C-F8312-00-P2	33 - 24	31D-H2151-00	41 - 6	55D-H4710-00	39 - 1	90149-06829	4 - 13
1DY-F4780-00	26 - 10	55D-F6210-00	30 - 1	55C-F8312-00-P4	33 - 24	4US-H2310-20	41 - 1	1VP-H4714-00	39 - 3	90150-05806	30 - 14
55C-F478E-10	26 - 18	1S8-F622F-00	30 - 30	55C-F8312-00-P7	33 - 24	55D-H2370-00	41 - 3	55D-H4721-10	39 - 2	90153-06803	1 - 3
1S8-F5168-00-0X	27 - 1	55C-F622H-00	30 - 29	55D-F8321-00	33 - 47	1S9-H2530-12	41 - 11	55D-H4723-10	39 - 5		1 - 25
1S8-F5168-00-P2	27 - 1	55C-F6240-00	30 - 20	55D-F8322-00	33 - 48	5YP-H2540-00	42 - 7	55D-H4735-10	39 - 4	90159-06033	26 - 17
3NA-F5181-01	27 - 8	1S8-F6241-00	30 - 22	1S8-F8336-00	33 - 50	55D-H2590-20	41 - 12	55C-H4759-00	39 - 7	90159-06181	21 - 9
5TN-F5190-01	27 - 11	1S8-F6242-00	30 - 21	55D-F8345-10-P0	33 - 2	55D-H3310-20	36 - 1	55D-H4781-00	38 - 5		21 - 13
5YP-F530K-00	29 - 8	55C-F6246-00	30 - 27	55D-F8345-10-P1	33 - 2	55D-H3311-00	36 - 3	55C-H4782-00	38 - 7		33 - 19
1S8-F5321-00-33	29 - 7	16S-F6257-00	30 - 28	55D-F8345-10-P2	33 - 2		36 - 6	55D-H4790-00	26 - 28		33 - 30
1S8-F5338-00-0X	29 - 1	2WB-F6280-00	30 - 23	55D-F8345-10-P3	33 - 2		36 - 9	1CJ-H5111-00	20 - 10		33 - 36

NUMERICAL INDEX

PART NO.	REF. NO.	PART NO.	REF. NO.	PART NO.	REF. NO.	PART NO.	REF. NO.	PART NO.	REF. NO.	PART NO.	REF. NO.
90159-06181	33 - 45	90201-122H1	34 - 6	90467-08003	21 - 29	90560-12145	29 - 2	93306-004XR	16 - 9	95307-06600	26 - 15
90163-05803	8 - 19	90201-126A7	18 - 15	90467-08075	25 - 12	91317-06014	14 - 9	93306-204YL	16 - 26	95307-08700	32 - 19
90170-05302	3 - 10	90201-12817	18 - 11	90467-08075	8 - 5	91317-06016	4 - 18	93306-252X1	16 - 10	95602-10200	22 - 13
	3 - 13	90201-15700	16 - 7		8 - 6		13 - 10	93306-300X8	27 - 4	95607-12200	29 - 26
90170-08258	29 - 22		16 - 23	90467-09006	21 - 30		34 - 4	93306-301YM	29 - 4	9560M-06100	31 - 9
90173-06015	38 - 3	90201-158D1	32 - 7		25 - 11	91317-06025	17 - 4	93306-301YN	29 - 3	95617-08620	1 - 5
90175-06013	32 - 14	90201-163H8	32 - 4	90467-10038	6 - 20		34 - 3	93306-305X7	2 - 7	95617-12100	22 - 7
90179-05802	30 - 13	90201-167P7	15 - 10	90467-12800	8 - 17	91317-06030	30 - 31	93310-325X1	14 - 10	95702-06500	20 - 11
90179-08818	19 - 8	90201-16803	13 - 6	90467-13064	8 - 27	91317-06100	1 - 22	93310-528X7	2 - 4	95707-06500	18 - 20
90179-10017	13 - 13	90201-25290	14 - 4	90467-13858	8 - 26	91317-10100	19 - 2	93340-212Y2	18 - 12		23 - 12
90179-10811	19 - 9	90201-26802	16 - 17	90467-14117	8 - 31	91401-20012	29 - 39	93410-20809	16 - 5	95707-08500	10 - 6
90179-12659	15 - 16	90202-05193	25 - 16	90467-15012	8 - 29		32 - 15	93410-22820	16 - 19	95707-10500	10 - 8
90179-14001	15 - 30	90202-15800	29 - 35		8 - 30	91401-30030	32 - 5	93450-16115	2 - 11	95707-12500	34 - 5
90179-25802	23 - 7	90209-17285	16 - 4	90480-01803	6 - 14		32 - 8	93503-16807	15 - 33	95807-06010	38 - 11
90183-05807	20 - 8	90209-18208	16 - 18	90480-01813	33 - 41	91701-08042	32 - 28	93602-08810	15 - 6	95807-06012	22 - 4
	21 - 2	90249-12008	32 - 13	90480-01868	19 - 14		32 - 36	93604-10837	18 - 13		23 - 20
	21 - 4	90252-23800	32 - 29		39 - 8	91811-10005	1 - 7	93604-12831	17 - 5		23 - 22
	21 - 7		32 - 37	90480-13805	21 - 21	92017-05025	7 - 3	93605-06002	4 - 4	95807-06020	21 - 20
	21 - 11	90280-03017	2 - 8	90480-13807	33 - 12	92017-06010	23 - 14	93822-15811	16 - 28		33 - 22
	21 - 33	90340-14824	12 - 7		39 - 9		23 - 18	93900-00817	27 - 6		33 - 33
	30 - 11	90340-32823	12 - 9	90480-13808	12 - 14	92017-06012	33 - 4		29 - 24		33 - 49
	30 - 17	90387-06063	12 - 15	90480-13867	33 - 13	92907-06600	32 - 16	94107-17873	27 - 5	95807-06025	12 - 13
	33 - 7	90387-061N0	26 - 21	90480-14872	26 - 13	92907-08200	29 - 37	94108-17868	29 - 23	95807-08012	42 - 20
	33 - 18	90387-06681	22 - 5	90480-15363	6 - 10	93101-10841	12 - 24	94568-84113	29 - 31	95807-08035	10 - 10
	33 - 29	90387-06804	20 - 4	90480-18418	33 - 20	93102-12883	18 - 5	94568-A8096	4 - 10	95827-06014	18 - 8
	33 - 42	90387-068B0	8 - 33		33 - 31	93102-16800	13 - 14	94668-84001	29 - 32		22 - 9
90183-06023	8 - 23	90387-07819	22 - 10	90501-030A0	14 - 8	93102-20881	16 - 27	94700-00884	1 - 18	95827-06016	6 - 11
90185-10091	27 - 9	90387-08822	10 - 13	90501-04801	15 - 14	93103-10801	5 - 2	95027-06010	4 - 9		20 - 2
90185-10154	23 - 10	90387-09801	33 - 21	90501-06022	17 - 7	93106-20816	27 - 3		16 - 30	95827-06020	26 - 20
90201-06069	6 - 12		33 - 32	90501-06800	17 - 10	93106-26815	29 - 16		41 - 8	95827-08016	32 - 22
90201-06071	26 - 14	90387-10277	27 - 7	90501-10245	32 - 12	93210-068E9	18 - 19	95027-06012	5 - 12	95827-10045	10 - 7
90201-06072	20 - 3	90387-10805	32 - 41	90501-125E9	18 - 14	93210-09805	4 - 2	95027-06014	1 - 11	97007-06016	41 - 2
90201-06557	33 - 23	90387-127Y0	29 - 17	90501-18576	7 - 6	93210-11802	1 - 15	95027-06020	1 - 12	97007-06025	25 - 5
	33 - 34	90401-10812	31 - 2	90506-12001	29 - 9	93210-14899	12 - 8	95027-06025	5 - 11	97007-08016	30 - 3
	33 - 5	90430-06817	1 - 4	90506-15001	29 - 10	93210-19809	5 - 15		5 - 13	97027-06016	8 - 34
90201-06822	42 - 4		1 - 13	90506-23804	32 - 20	93210-198F0	12 - 23	95027-06050	5 - 14	97027-08020	18 - 24
90201-06830	26 - 24		1 - 26	90506-35806	32 - 6	93210-21800	42 - 8	9502L-06012	7 - 13	97607-04114	9 - 26
90201-06882	26 - 7	90430-12801	42 - 11	90508-40801	32 - 10	93210-26801	35 - 6	9502L-06020	7 - 10	97607-05216	40 - 7
90201-068N7	1 - 17	90445-07812	25 - 8	90520-02806	21 - 5	93210-32803	12 - 10	9502L-06040	12 - 4	97607-06212	42 - 13
90201-08609	10 - 11	90445-09823	21 - 27	90520-02807	21 - 32	93210-32807	8 - 1		12 - 20	9760L-04212	31 - 11
90201-08612	30 - 5	90450-27803	6 - 16	90520-02813	30 - 2	93210-34801	7 - 7	9502L-06045	11 - 5	97707-40616	39 - 6
	19 - 6		6 - 18	90520-04804	42 - 3	93210-41041	29 - 5	9502L-06050	11 - 4	97707-50012	21 - 8
90201-08804	29 - 36	90462-08814	8 - 20	90520-04806	21 - 14	93210-59800	7 - 11		12 - 5		21 - 12
90201-10118	31 - 3	90462-08817	12 - 6	90520-04813	30 - 9	93210-84801	5 - 6		12 - 21		21 - 16
90201-10141	10 - 9	90464-24803	30 - 36	90520-05806	33 - 10	93306-000Y3	5 - 10	9502L-06060	11 - 3		30 - 19
90201-101J1	19 - 7	90464-50800	42 - 16	90520-10810	33 - 11	93306-001X2	4 - 3		12 - 25		33 - 38
	27 - 10	90464-50801	33 - 51	90520-96802	42 - 6	93306-002X8	16 - 25	95304-08700	29 - 38		33 - 40
90201-12019	15 - 15	90467-07029	8 - 9	90560-10292	27 - 2	93306-004XB	29 - 18	95307-06600	26 - 8		40 - 8

NUMERICAL INDEX

PART NO.	REF. NO.	PART NO.	REF. NO.	PART NO.	REF. NO.	PART NO.	REF. NO.	PART NO.	REF. NO.	PART NO.	REF. NO.
97707-50012	40 - 10										
97707-50014	30 - 10										
	30 - 18										
	33 - 8										
	33 - 17										
	33 - 28										
	33 - 43										
	33 - 46										
97707-50016	36 - 7										
	37 - 5										
	38 - 6										
	38 - 8										
97707-50025	37 - 6										
98507-04008	9 - 14										
98507-04014	9 - 22										
98507-04018	9 - 17										
98507-05008	9 - 16										
98507-05010	9 - 18										
	26 - 26										
98507-05016	30 - 26										
	42 - 9										
98507-05025	30 - 35										
98507-06012	26 - 11										
	42 - 5										
98507-06020	26 - 23										
9850L-06008	40 - 5										
98517-06012	16 - 12										
9870M-04012	31 - 15										
99009-15400	16 - 8										
	16 - 24										
99009-28400	15 - 8										
99530-10114	1 - 20										
	1 - 21										
	11 - 2										
	12 - 3										
	12 - 19										